

# Unit 2 Electricity and Energy

## Electric Current

N4

Materials can be divided into two main groups as conductors and insulators

Electrical conductors contain electrons which are free to move throughout the structure.

In electrical insulators, the electrons are tightly bound and cannot move.

All circuits need a source of energy and some electrical components which are connected by wires. The source of energy may be a battery or the mains.

If a battery is connected across a conductor such as a bulb, then the electrons will move in one direction around the circuit:

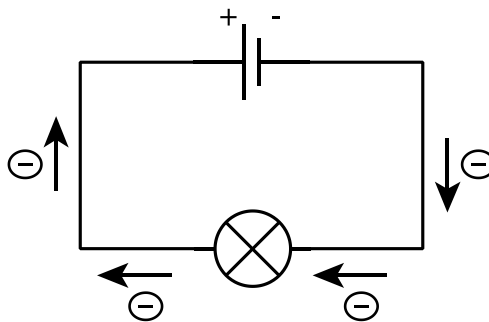

An **electric current** is the flow of electrons around a circuit. The greater the flow of electrons in a circuit, the greater is the current.

The **voltage** is the electrical energy supplied by the battery (or mains) to make the electrons move around the circuit.

## Series Circuits

When components are connected in line, we say that they are connected in series.



The three bulbs are connected in series

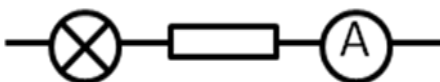

The bulb, resistor and ammeter are connected in series.

If the components form a circuit, the circuit is called a **series circuit**.

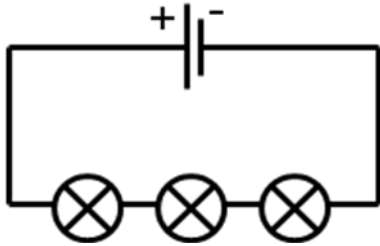

In the circuit, the current from the battery passes through each of the bulbs in turn before returning to the battery.

The cell and the three bulbs are connected in series. In a series circuit, there is only one path for the current to take from the negative terminal of the battery to the positive terminal.

### Parallel Circuits

When components are connected so that there is more than one path for the current, we say that they are connected in parallel.

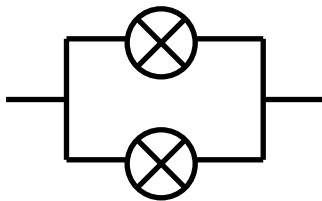

The two bulbs are connected in parallel

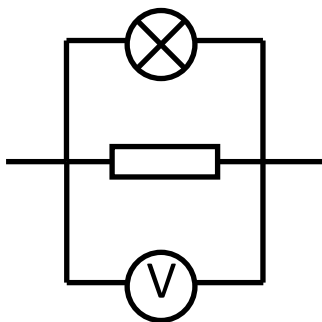

The bulb, resistor and voltmeter are connected in parallel

If the components form a circuit, the circuit is called a **parallel circuit**.

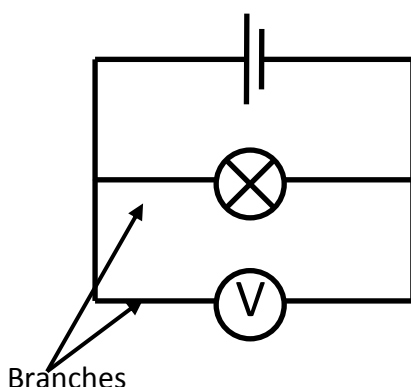

In the circuit, the current from the battery splits up and goes through each of the components (or branches) separately before recombining and returning to the battery

The cell, bulb and voltmeter are connected in parallel. In a parallel circuit, there is more than one electrical path (or branch) for the current to take from the negative terminal to the positive terminal of the battery.

### Measuring Current

Current is measured using an ammeter which has the symbol:



Electric current is given the symbol  $I$  and is measured in amperes (A)

To measure the current through a component, make a gap in the circuit and connect the ammeter in series with the component.

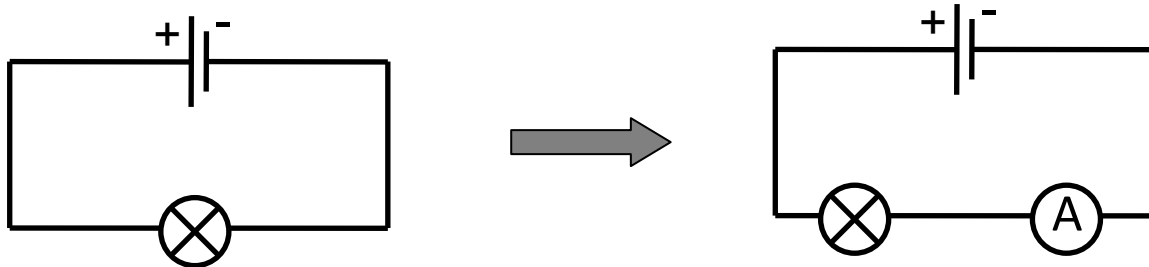

In the circuit, the ammeter is in series with the bulb. The reading on the ammeter is the current through the bulb.

### Measuring Voltage

Voltage is measured using a voltmeter which has the symbol:



Electrical voltage is given the symbol  $V$  and is measured in volts (V).

To measure the voltage across a component, use two extra wires to connect the voltmeter in parallel with the component.

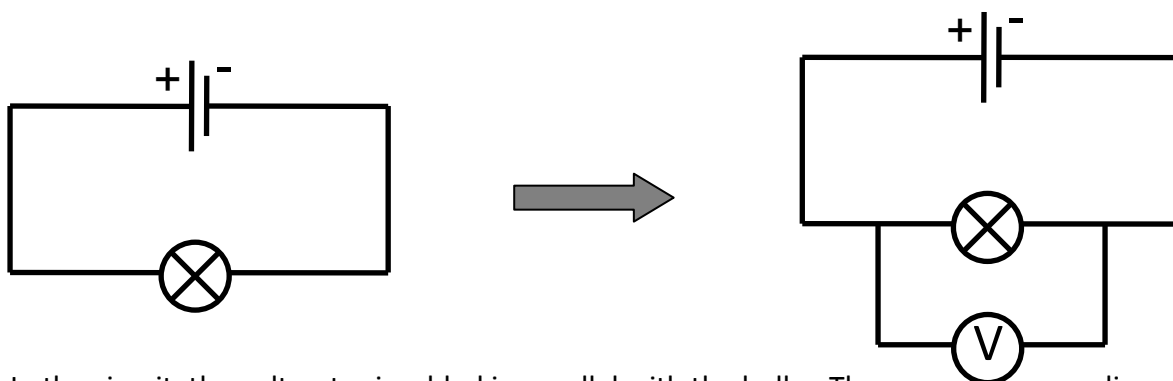

In the circuit, the voltmeter is added in parallel with the bulb. The reading on the voltmeter is the voltage across the bulb.

## Current and voltage in series circuits

The current through every component in a series circuit is identical and is the same as the current from the battery.

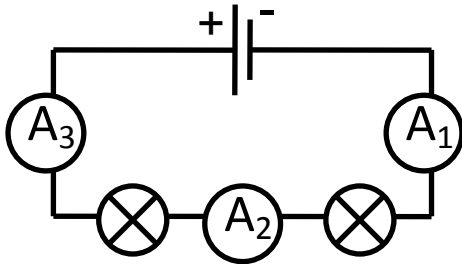

Each ammeter will have the same reading.

$$A_1 = A_2 = A_3$$

The sum of the voltages across each component in a series circuit adds up to the supply voltage.

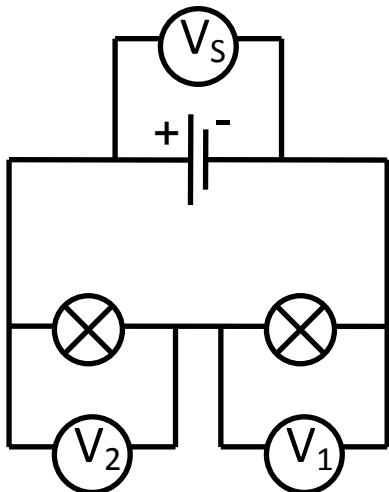

The voltmeter readings across the lamps in this circuit add up to the voltage across the battery.

$$V_S = V_1 + V_2$$

### Examples

1. In the circuit shown below, the current readings on  $A_1$  is 0.2 A. What is the current reading on the other ammeter and through each lamp?

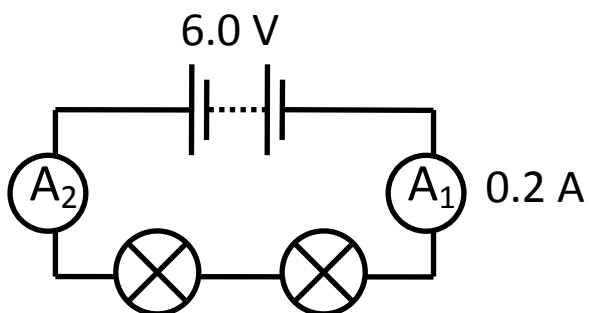

In a series circuit, the current is the same at all points.

Reading on  $A_2 = 0.2 \text{ A}$

Current through each lamp = 0.2 A

2. Find the voltage of the battery in the circuit shown below.

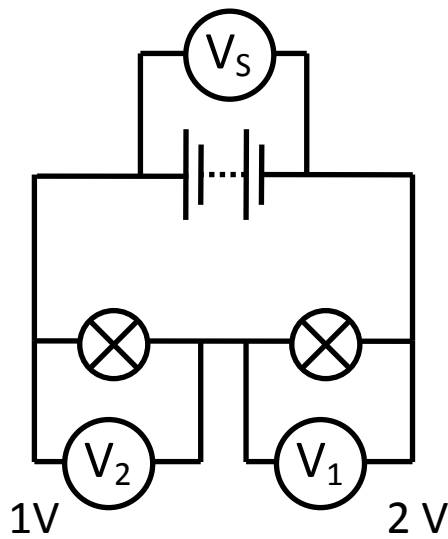

In a series circuit, the voltage across each component adds up to the supply voltage.

So the battery voltage = 2 + 1 = 3 V

### Current and voltage in parallel circuits

The sum of the currents through each component (branch) in a parallel circuit, adds up to the current which flows from the supply.

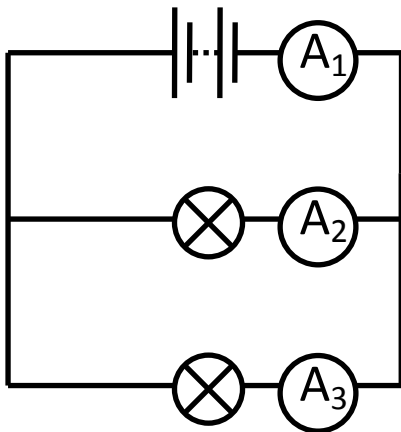

The currents through each component (branch) add up to the current from the battery.

$$A_1 = A_2 + A_3$$

The voltage across every component (branch) in a parallel circuit is the same as the supply voltage.

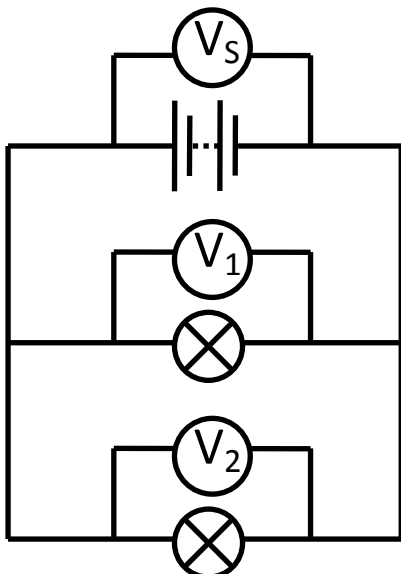

Each voltmeter has the same reading.

$$V_S = V_1 = V_2$$

The supply voltage is the same as the voltage across each of the components in parallel.

## Examples

1. In the circuit shown below, the current from the battery flows through two identical bulbs. What are the current readings on  $A_2$  and  $A_3$ ?

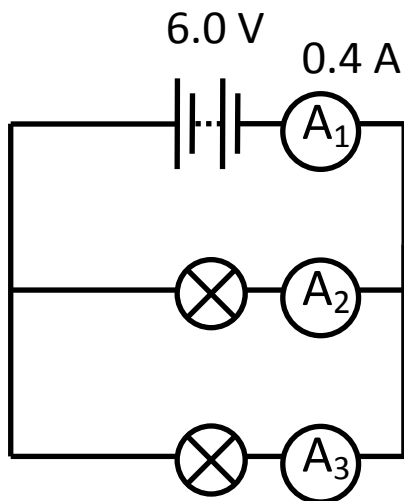

In a parallel circuit, the current from the battery is divided equally between the branches as the bulbs are identical.

So the current through each bulb =  $0.4/2 = 0.2$  A

2. The voltage across the battery is 6.0 V. What is the voltage across the two bulbs?

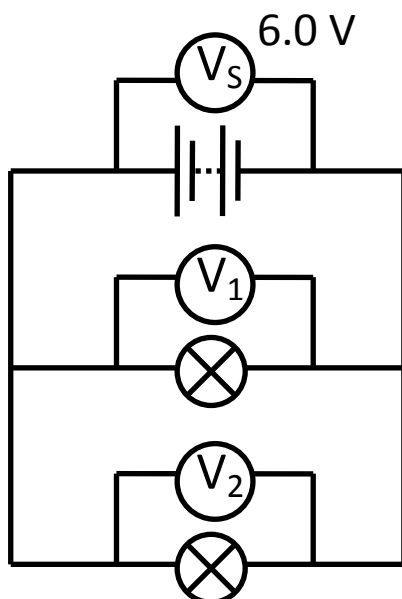

In a parallel circuit, the voltage across each of the components in parallel is the same as the supply voltage.

So the voltage across  $V_S = V_1 = V_2$

Therefore the voltage across each bulb is 6.0 V

## Practical uses of series and parallel circuits

### Car lights:

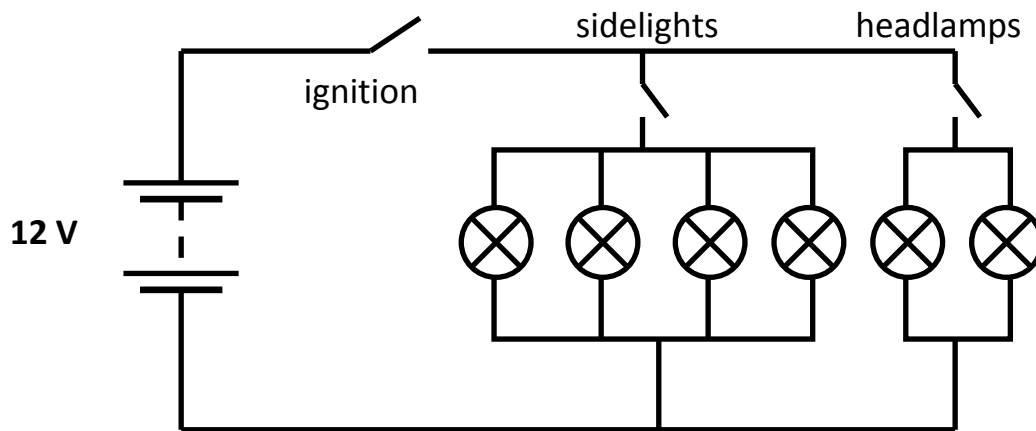

All the bulbs are placed in parallel with the battery so that each has 12 V across it.

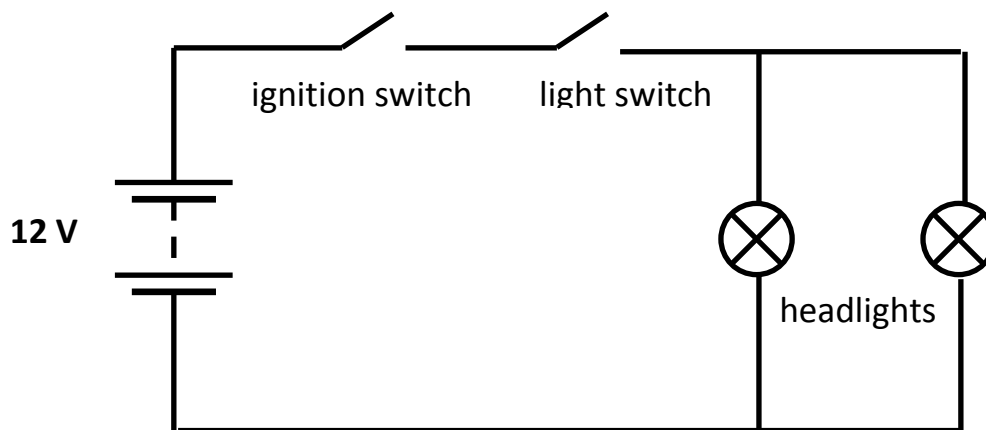

The two headlights are connected across the battery. They operate together only when the ignition switch and the light switch are on. The headlights are connected in parallel while the switches are connected in series.

### **Resistance**

When an electric current flows through a wire some of the electrical energy is changed to heat in the wire. All materials oppose the current passing through them. This opposition to current flow is called resistance. The resistance is a measure of the opposition to the flow of current in a circuit. Insulators have a high resistance, while conductors have a low resistance.

The symbol for resistance is R and resistance is measured in units of ohms ( $\Omega$ ).

Electrical resistance is measured using an ohmmeter which has the symbol:



To measure the resistance of a component, an ohmmeter is connected directly across the component which must be disconnected from the circuit:

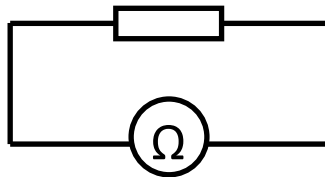

The larger the resistance in a circuit, the smaller the current that flows in it.

The smaller the resistance in a circuit, the larger the current that flows in it.

The resistance of a material depends on a number of factors:

Type of material – the better the conductor, the lower the resistance

Length of material – the longer the material, the higher the resistance

Thickness of material – the thicker the material, the lower the resistance

Temperature of material – for most conductors, the higher the temperature, the higher the resistance

### Ohm's Law

In a conductor at constant temperature, the current increases as the voltage is increased.

Therefore, the ratio of  $V/I$  remains constant and is known as the resistance.

Therefore,

$$\text{Resistance} = \frac{\text{voltage}}{\text{current}}$$

$$R = \frac{V}{I}$$

Ohms or  $\Omega$

Volts or **V**

Amperes or **A**



### Example

The current flowing through a resistor is 0.5 A and the voltage across it is 6.0 V.

Calculate the resistance.

### Solution

$$V = 6 \text{ V}$$

$$I = 0.5 \text{ A}$$

$$R = ?$$

$$R = V/I$$

$$= 6.0 / 0.5$$

$$= \underline{12 \Omega}$$

### **Variable Resistors**

Resistors are components that have the property of electrical resistance. Resistors transform electrical energy into heat in domestic appliances such as heaters, toasters etc. Resistors are used also to limit the current in electronic circuits.

A variable resistor can alter the current in a circuit by changing the resistance in the circuit.

The symbol for a variable resistor is:



Practical uses for variable resistors include:

- Light dimmer controls
- Volume and brightness controls
- Speed controls on electric motors.



## Alternating and Direct Current

Figure 1 and Figure 2 show the electron directions for each type of current flow as viewed on an oscilloscope.

Figure 1

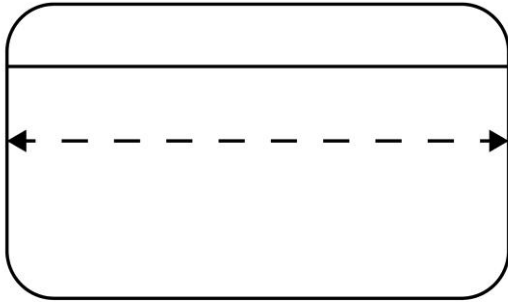

Direct Current (d.c)

Figure 2

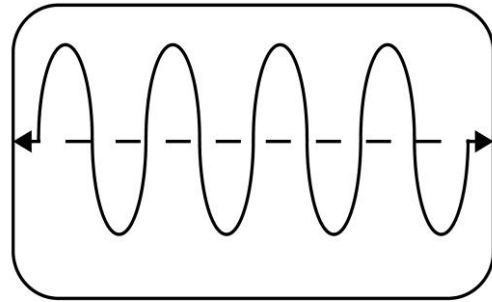

Alternating Current (a.c)

- Figure 1, direct current shows that electrons always flow in one direction around the circuit.
- Figure 2, alternating current shows that electrons flow around in one direction then the direction changes and the electrons flow in the opposite direction.

Alternating and direct currents are produced from different sources of electrical energy. Alternating current is produced from the mains supply and direct current from a battery.

## Electric field

An electric field is a region of space in which a charge placed in that region will experience a force.

Below is a diagram of the electric field between two parallel charged plates. The normally invisible electric field lines have been drawn to show the direction of the electric field.

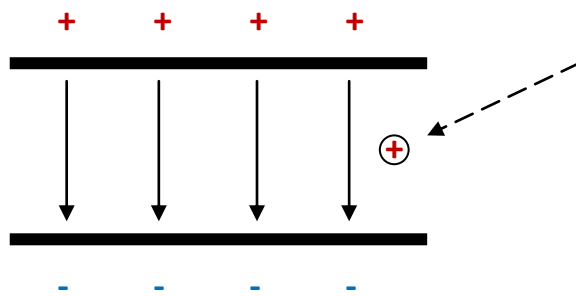

The direction of the electric field is the direction of the force experienced by a positive charge placed in the field.

The diagram shows the positive charge being accelerated towards the negative plate, due to both repulsion of the positive plate and the attraction to the negative plate.

If a *negative charge* was placed in the electric field it would be *accelerated towards the positive plate*, due to both repulsion of the negative plate and the attraction to the positive plate.

The parallel plates will have a voltage across them this called *the potential difference*, symbol  $V$ , measured in volts,  $V$ .

The potential difference is a measure of the energy given to the charges when they move between the plates.

**Potential difference is equal to the work done in moving one coulomb of charge between the plates.** Therefore a potential difference of one volt indicates that one joule of energy is being used to move one coulomb of charge between the plates.

## Complex Circuits with Current and Voltage

### Series Circuit

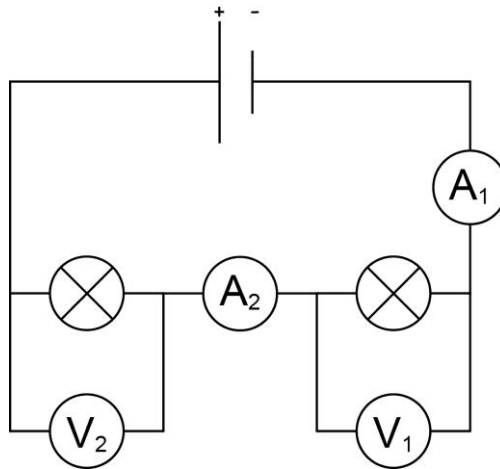

All bulbs are identical

- (a)  $V_1$  reads 3 V, what does  $V_2$  read?

**$V_2$  reads 3V since the bulbs are identical each bulb gets the same share of the voltage.**

- (b) Hence, calculate the voltage supply.

$$\mathbf{V_s = V_1 + V_2 \quad \text{therefore} \quad V_s = 3 + 3 = 6V}$$

- (c) The reading on ammeter  $A_2$  is 1 A, what will the reading be on  $A_1$ ?

**The current is the same at all points in a series circuit therefore  $A_1$  will read 1 A.**

## Parallel Circuit

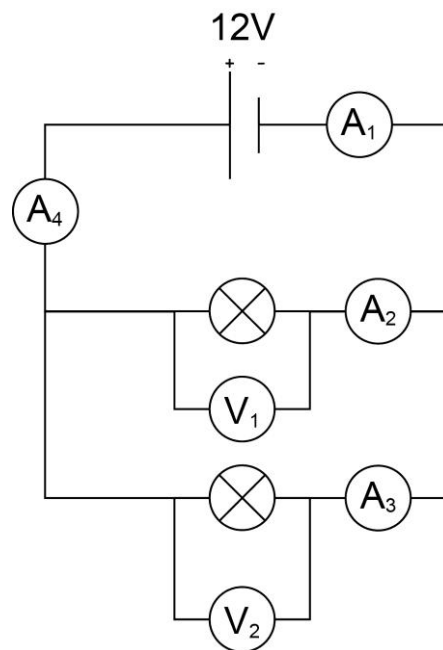

All bulbs are identical

(a) What are the readings on voltmeters V<sub>1</sub> and V<sub>2</sub>?

**Both read 12 V, since in parallel each branch of the circuit receives the same voltage as the voltage supply.**

(b) If A<sub>1</sub> reads 3A, calculate the readings on A<sub>2</sub>, A<sub>3</sub> and A<sub>4</sub>.

**The current will split equally between both branches since the bulbs are identical.**

**Therefore, A<sub>2</sub> and A<sub>3</sub> will both read 1.5A.**

**A<sub>4</sub> will read 3A since this is the point in the circuit where the current recombines.**

### Combined series and parallel circuits

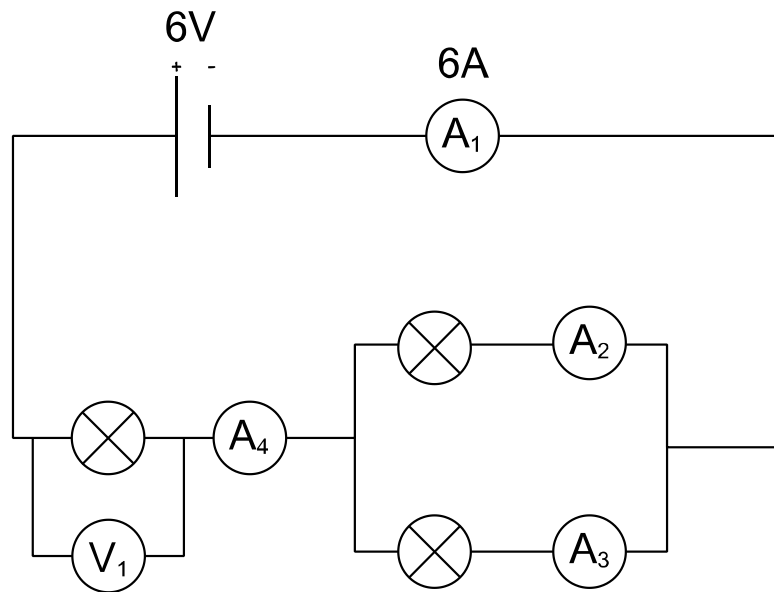

All bulbs are identical

(a) A<sub>1</sub> reads 6A, what are the readings on A<sub>2</sub>, A<sub>3</sub> and A<sub>4</sub>?

**A<sub>2</sub> and A<sub>3</sub> = 3A, since the supply current is split between both branches equally.**

**A<sub>4</sub> = 6A, at this point the current recombines.**

(b) What is the reading on V<sub>1</sub>?

**The parallel arrangement of bulbs will have half the resistance of the single bulb.**

**Therefore the parallel bulbs will receive only half the voltage the single bulb will get.**

**V<sub>1</sub> will read 4V and each bulb will receive only 2V.**

[This is explained under the heading resistance in parallel]

## Calculations involving resistors in series and parallel

### Resistors in Series

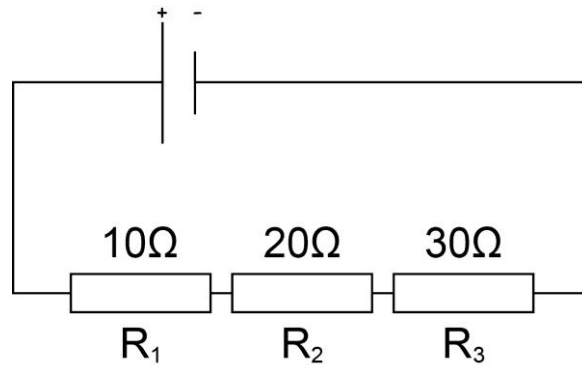

The **total resistance** of all three resistors in series is calculated using the following equation:

$$R_T = R_1 + R_2 + R_3$$

$$R_T = 10 + 20 + 30$$

$$R_T = 60 \Omega$$

### Resistors in Parallel

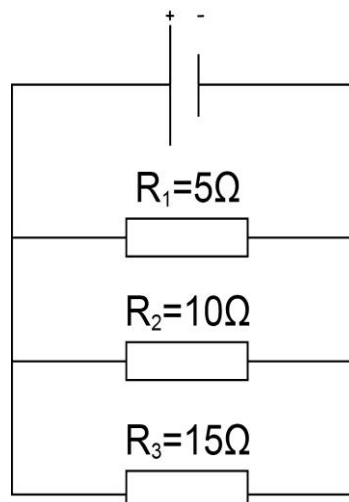

The **total resistance** of all three resistors in parallel is calculated using the following equation:

$$\frac{1}{R_T} = \frac{1}{R_1} + \frac{1}{R_2} + \frac{1}{R_3}$$



Therefore

$$\frac{1}{R_T} = \frac{1}{5} + \frac{1}{10} + \frac{1}{15}$$

- Multiply both the top and bottom of each fraction to make all the denominators the same.

$$\frac{1}{R_T} = \frac{6}{30} + \frac{3}{30} + \frac{2}{30}$$

- Add fractions

$$\frac{1}{R_T} = \frac{11}{30}$$

- Invert to calculate  $R_T$

$$\frac{R_T}{1} = \frac{30}{11} = 2.72\Omega$$

### More on resistors in parallel

Shown below is a simple series circuit complete with a  $5\Omega$  resistor.

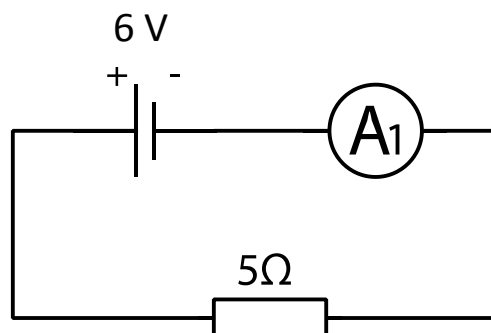

Calculate the value of current through the resistor.

$$\left. \begin{array}{l} V = 6 \text{ V} \\ R = 5 \Omega \\ I = ? \end{array} \right\}$$

$$V = I \times R$$

$$6 = I \times 5$$

$$6/5 = I$$

$$1.2 \text{ A} = I$$

Now add another 5 Ω resistor in parallel to the original, the circuit now looks like:

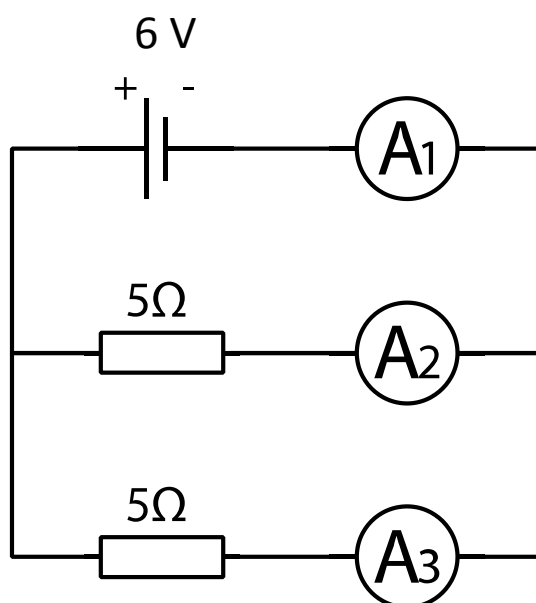

Calculate the value of the current through ammeter A<sub>1</sub>.

- To do this the total resistance of the circuit must be calculated first.

**Step 1**

- $\frac{1}{R_T} = \frac{1}{R_1} + \frac{1}{R_2}$

$$\frac{1}{R_T} = \frac{1}{5} + \frac{1}{5}$$

$$\frac{1}{R_T} = \frac{2}{5}$$

$$R_T = 2.5 \Omega$$

**Step 2**

$$V = I \times R$$

$$6 = I \times 2.5$$

$$6 / 2.5 = I$$

$$2.4 \text{ A} = I$$

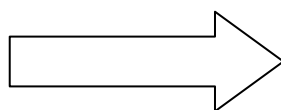

This result shows that when another resistor is added in parallel the total resistance of a circuit is decreased and the current in the circuit is increased.

i.e. by adding an identical resistor in parallel the resistance has halved and the current drawn doubled.

### Determining the relationship between V (p.d), current and resistance

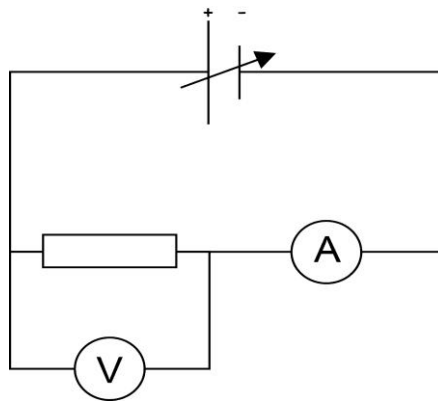

- Using a fixed value of resistor, vary the voltage supply to the circuit.
- Measure and note the values of voltage and current.
- Draw a graph of p.d against I, as shown below

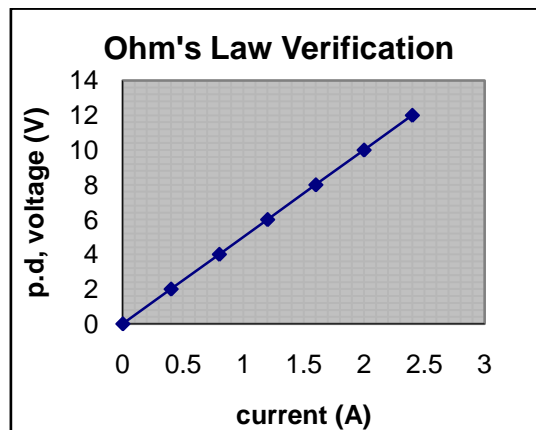

This graph shows that

$$V \propto I$$

$$V = I \times \text{constant}$$

$$\frac{V}{I} = \text{constant}$$

This constant =  
gradient of the line

Pick values of potential difference and current from the graph to show that:  $V/I = \text{constant}$ .

Potential difference (V)	Current(A)	$V/I = \text{constant}$
2	0.4	5
4	0.8	5
6	1.2	5
8	1.6	5
10	2.0	5
12	2.4	5

Which quantity from the experiment is equal to a constant value of 5?

- **The size of the resistor.**

Therefore  $V = I \times R$  and rearranged gives

$$\frac{V}{I} = R$$

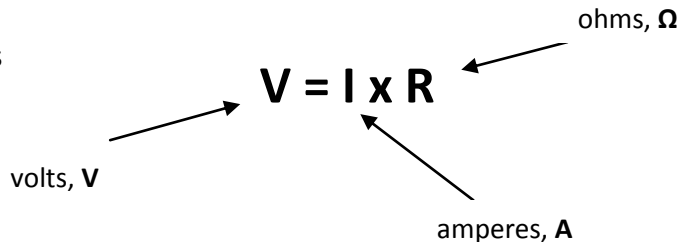

**Carry out calculations using  $V = I \times R$**

**Example 1**

A mobile phone has a resistance of  $4 \Omega$  and a current of 3 A passing through it, calculate the size of voltage it uses.

$V = ?$ $R = 4\Omega$ $I = 3A$	}	$V = I \times R$ $V = 3 \times 4$ $V = 12 V$
--------------------------------------	---	--

**Example 2**

The lamp has a voltage of 230 V and a resistance of  $83 \Omega$ , calculate the current passing through the lamp.

$V = 230V$ $R = 83\Omega$ $I = ?$	}	$V = I \times R$ $230 = I \times 83$ $230 = I$ <hr style="width: 10px; margin: 0 auto;"/> $83$ $2.8 A = I$
---	---	--

**Example 3**

An electric fire has a voltage of 230 V and a current of 5 A, calculate the resistance of the fire.

$V = 230V$ $R = ?$ $I = 5A$	}	$V = I \times R$ $230 = 5 \times R$ $230 = R$ <hr style="width: 10px; margin: 0 auto;"/> $5$ $46 \Omega = R$
-----------------------------------	---	--

## The resistance of a conductor varies with temperature

A bulb is an example of a non-ohmic resistor.

This means that as the filament of the bulb is heated by the passage of current through it, its resistance is increased.

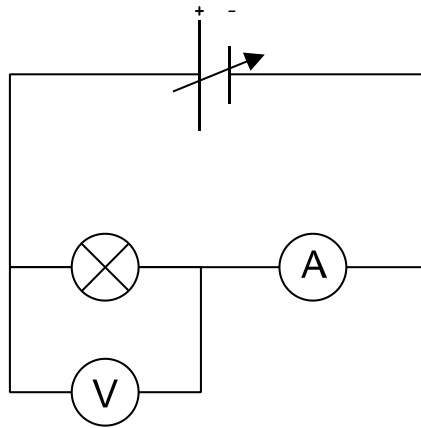

Increasing the voltage to the bulb, causes the voltage and current to the bulb to change, as shown in the graph below

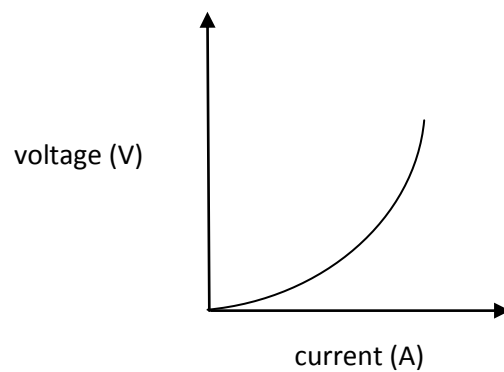

- This shows that voltage is not directly proportional to current and therefore does not follow Ohm's Law.
- As the tungsten filament is heated its resistance increases.

## Electrical Power

N4

All electrical appliances convert electrical energy into other forms of energy. Energy has the symbol E and is measured in units of joules, J.

All appliances have a known power rating which can be found on the appliance's rating plate. Power has the symbol P and is measured in units of watts, W. The power rating of an appliance is measured as the number of joules of energy it transforms per second.

The table below shows some household appliances along with their main energy transformation and their typical power rating.

Appliance	Main energy transformation	Power (watts, W)
Lamp	Electrical into light	60
Toaster	Electrical into heat	1100
Food mixer	Electrical into kinetic	120
Radio	Electrical into sound	630

The number of joules of energy an appliance uses depends on two factors:

1. how long the appliance is on
2. the power rating of the appliance

Therefore the longer an appliance is on and the greater its power rating the more electrical energy it will use.

## Energy Consumption

In a world concerned with saving energy, it is necessary to be able to calculate the energy consumption of different appliances in order that we make an informed decision on which appliances we may want to purchase.

This can be calculated using the following equation:

energy = power x time

$$E = P \times t$$

joules, J

watts, W

seconds, s

### Example

A typical washing machine is rated 1200W. It is switched on for a washing cycle of 60 minutes how much energy does it consume during this cycle?

$P = 1200W$	}	$E = P \times t$
$t = 60 \times 60 = 3600s$		$E = 1200 \times 3600$
$E = ?$		$E = 4320000 J$

## Calculations involving power, energy and time

N5

### Example 1

A typical washing machine is rated 1200W. It is switched on for a washing cycle of 60 minutes, how much energy does it consume during this cycle?

$$\left. \begin{array}{l} P = 1200\text{W} \\ t = 60 \text{ minutes } (60 \times 60 = 3600\text{s}) \\ E = ? \end{array} \right\}$$
$$\begin{array}{l} E = P \times t \\ E = 1200 \times 3600 \\ E = 432\,0000 \text{ J} \end{array}$$

### Example 2

A toaster switched on for 5 minutes uses 330,000 J of energy, calculate its power.

$$\left. \begin{array}{l} P = ? \\ t = 5 \text{ minutes } (5 \times 60 = 300\text{s}) \\ E = 330,000 \text{ J} \end{array} \right\}$$
$$\begin{array}{l} E = P \times t \\ 330,000 = P \times 300 \\ 330,000 = P \\ \hline 300 \\ 1100 \text{ W} = P \end{array}$$

### Example 3

The power rating of a lamp is 60 W, during the time it has been on it has used up 10,000 J of electrical energy. For how long was the lamp on?

$$\left. \begin{array}{l} P = 60 \text{ W} \\ t = ? \\ E = 10,000 \text{ J} \end{array} \right\}$$
$$\begin{array}{l} E = P \times t \\ 10,000 = 60 \times t \\ 10,000 = t \\ \hline 60 \\ 167 \text{ s} = t \end{array}$$



The **electrical energy transformed each second** is equal to  $P = I \times V$

**Explain the equivalence of  $P = I \times V$  and  $P = I^2 R$  and  $P = V^2 / R$**

The power equation  $P = I \times V$  can be arranged for use with other quantities.

### Example 1

$$V = I \times R \quad \text{and} \quad P = I \times V$$

$$P = I \times (I \times R)$$

$$P = I^2 R$$

### Example 2

$$I^2 = V^2 / R^2 \quad \text{and} \quad P = I^2 R$$

$$P = V^2 / R^2 (x R)$$

$$P = V^2 / R$$

### Carry out calculations involving P, I, V and R

#### Example 1

A torch bulb has a voltage of 6 V and a current of 0.3 A passing through it. What is its power?

$$\left. \begin{array}{l} V = 6 \text{ V} \\ I = 0.3 \text{ A} \\ P = ? \end{array} \right\} \begin{array}{l} P = I \times V \\ P = 0.3 \times 6 \\ P = \mathbf{1.8 \text{ W}} \end{array}$$

#### Example 2

A car headlamp has a power of 24 W and a resistance of 6  $\Omega$ . Calculate its voltage supply.

$$\left. \begin{array}{l} P = 24 \text{ W} \\ R = 6 \Omega \\ V = ? \end{array} \right\} \begin{array}{l} P = V^2/R \\ 24 = V^2 / 6 \\ 24 \times 6 = V^2 \\ 144 = V^2 \\ \sqrt{144} = V \\ \mathbf{12 \text{ V} = V} \end{array}$$

#### Example 3

An electric heater has a voltage supply of 240 V and a power of 960 W. Calculate the current passing through it then the resistance of its elements.

$$\left. \begin{array}{l} V = 240 \text{ V} \\ P = 960 \text{ W} \\ I = ? \\ R = ? \end{array} \right\} \begin{array}{l} \textbf{Step 1} \\ P = I \times V \\ 960 = I \times 240 \\ 960 / 240 = I \\ \mathbf{4 \text{ A} = I} \end{array} \quad \text{Then} \quad \begin{array}{l} \textbf{Step 2} \\ P = I^2 \times R \\ 960 = (4 \times 4) \times R \\ 960/16 = R \\ \mathbf{60 \Omega = R} \end{array}$$

## Electromagnetism

N5

When there is an electric current flowing in a wire, a magnetic field exists around the wire.

The magnetic affect of the current is used in a number of applications as follows:

### (i) Electromagnets

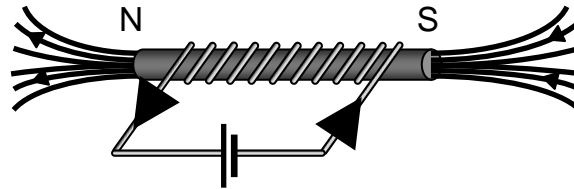

An electromagnet is made by wrapping a coil of wire around an iron core. When a current is passed through the coil of wire, the core is magnetised. The magnetic field is much stronger with the core present than without it. The magnetic field can be switched off by switching off the electric current. The magnetic field can also be made stronger by increasing the current through the wire or increasing the number of turns on the coil.

### (ii) Relays

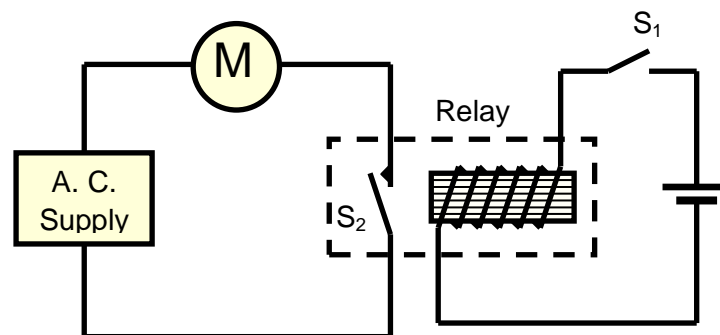

In a relay low voltage circuit is used to control remotely a high voltage circuit

When switch  $S_1$  is closed, a current passes through the coil of a relay in the first circuit. The electromagnet attracts and closes switch  $S_2$  in the second circuit. This completes the circuit which turns on the motor. When switch  $S_1$  is opened, the motor is turned off.

### (iii) Electric bells

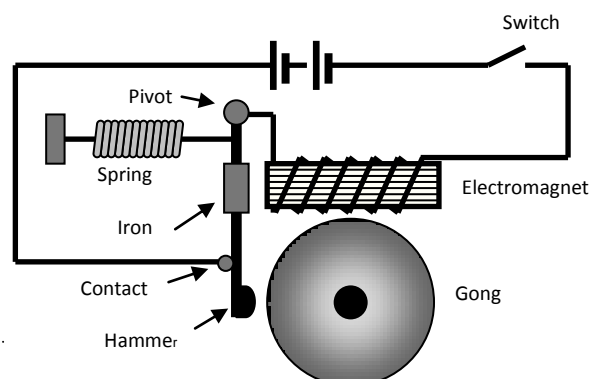

Closing the switch de-magnetises the electromagnet which attracts the iron causing the hammer to strike the gong. The movement of the iron breaks the circuit, de-magnetising the magnet so that the spring pulls back the hammer and remakes the circuit. Current passes through the electromagnet again and the sequence is repeated.

### Induced Voltage

A voltage is induced in a coil of wire (or any conductor) when the coil of wire is moving across a magnetic field or the coil of wire is placed within a changing magnetic field.

The size of the induced voltage depends on the strength of the magnetic field, the number of turns on the coil and the speed of movement.

If the coil of wire is part of a complete circuit, the induced voltage will drive a current round the circuit.

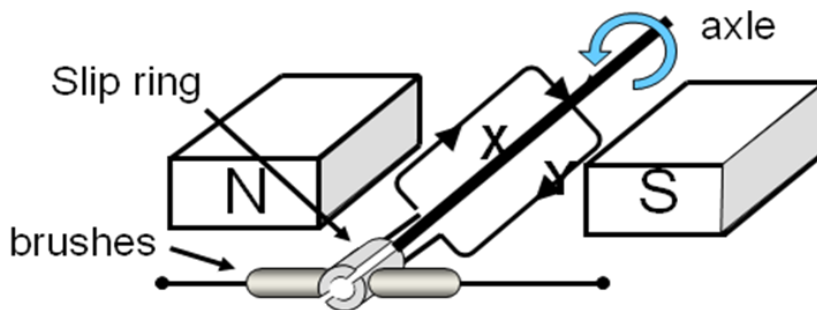

In a simple a.c. generator, a coil of wire is rotated in a magnetic field. This induces a voltage in the coil. When the coil is connected to a circuit via the slip rings and brushes, the induced voltage causes a current to flow in the external circuit. When the coil rotates through  $180^\circ$ , the direction of movement of the coil through the magnetic field is reversed so the induced voltage is also reversed. This causes the current to change direction. This process is repeated each time the coil turns through  $180^\circ$  to produce an alternating current.

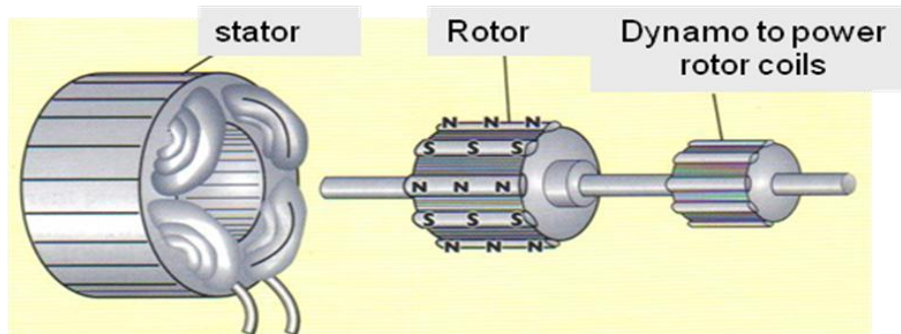

In a full-size generator, the magnet is replaced by a rotating electromagnet known as the **rotor coils**. Instead of a rotating coil, the a.c. voltage is induced in a series of static coils called a **stator**.

### Fossil fuels

Most of the world's energy is obtained from **fossil** fuels such as coal, oil and gas found in the Earth's crust. Fossil fuels are made from the remains of plants and tiny animals that lived millions of years ago. These fuels consist mainly of hydrocarbons which release large amounts of energy when burned.

Fossil fuels take millions of years to form and are being used up faster than they can be replaced so they will eventually run out. Fuels that will eventually run out are said to be **finite**.

Pollution from fossil fuels contributes to global warming and causes acid rain.

### Renewable and non-renewable sources of energy

Energy sources can be classified into two groups: **renewable and non-renewable**.





Fossil fuels take millions of years to form under the Earth's crust. Uranium used in nuclear fuels is also produced over millions of years by geological processes. Peat is formed over thousands of years in wet areas from a build up of partially decayed vegetation. We are using up these fuels much faster than they can be replaced. Therefore, coal, oil, gas, peat and uranium are considered **non-renewable** energy sources.



Alternative sources of energy are generated from natural resources such as sunlight, wind, rain, waves, tides and plants. These sources are considered **renewable** because they quickly replenish themselves and are usually available in a never ending supply.

A summary of renewable and non-renewable energy sources is given in the table:

Renewable	Non-renewable
Solar	coal
wind	oil
waves	gas
tidal	peat
geothermal	nuclear
hydroelectric	
biomass	

## Advantages and disadvantages of renewable energy sources

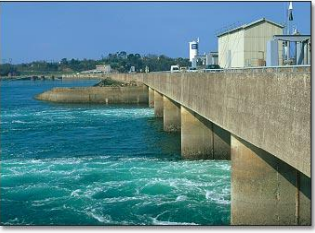
Energy Source	Diagram	Description	Advantages/Disadvantages
Solar		<p>Heat from the sun can be used to generate electricity directly using photocells similar to those found in solar powered calculators.</p>	<p><b>Advantages:</b> Solar energy will never run out. It does not pollute the atmosphere.</p> <p><b>Disadvantages:</b> Installations are expensive. It is not always sunny.</p>
Wind		<p>The kinetic energy of the wind rotates a large propeller which turns a generator to produce electricity.</p>	<p><b>Advantage:</b> Wind power will never run out.</p> <p><b>Disadvantages:</b> The wind does not always blow. Wind turbines are unsightly. Windmills require a lot of land.</p>
Hydro electricity		<p>Water stored behind a dam is allowed to flow down the hill to drive a large turbine and generator which produces electricity.</p>	<p><b>Advantage:</b> Electricity available when required.</p> <p><b>Disadvantages:</b> Building dams and flooding valleys destroys areas of natural beauty and kills large numbers of wildlife.</p>
Wave		<p>Movement of the waves can be changed into electrical energy using the motion of the waves to turn a turbine and generator to produce electricity.</p>	<p><b>Advantage:</b> Wave energy will never run out.</p> <p><b>Disadvantages:</b> Wave equipment is expensive and may be a danger to ships. Waves vary in size.</p>

<p>Tidal</p>		<p>Large quantities of water are trapped behind tidal barrages. On the outgoing tide, the water is released and used to drive water turbines to produce electricity.</p>	<p><b>Advantage:</b> Tidal energy will never run out. <b>Disadvantages:</b> There are few suitable locations. The eco system near the dam is changed drastically.</p>
<p>Geo-thermal</p>		<p>Heat inside the earth can be used to heat water. Steam formed when the water boils can be used to drive a turbine to generate electricity.</p>	<p><b>Advantage:</b> Geothermal energy is renewable. <b>Disadvantages:</b> There are only a few useful locations Deep drilling is expensive.</p>
<p>Biomass</p>		<p>Wood and plants may be burned to produce energy.</p> <p>Alcohol may be distilled from plants and used to fuel cars.</p>	<p><b>Advantage:</b> Biomass is renewable. <b>Disadvantage:</b> Plant growth is too slow to provide large amounts of energy.</p>

## Transformers

A transformer is a device that can change the size of an ac voltage. A transformer can either **increase** or **decrease** the **size of a voltage**.

### Structure of Transformer

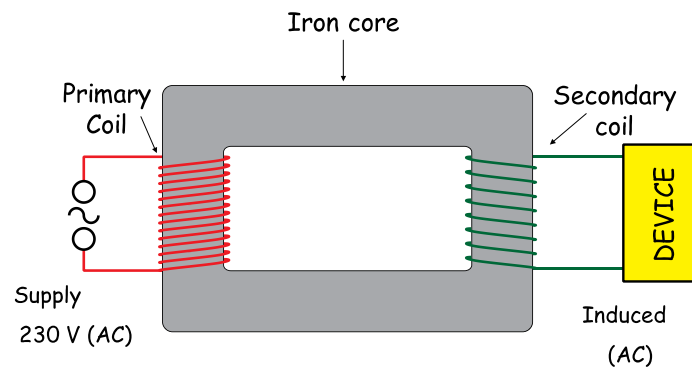

### How does a transformer work?

- An **AC voltage** is applied to the **primary coil**.
- This **INDUCES** a changing **magnetic field** around the **primary coil** and iron core.
- The **secondary coils** are **within the range** of this changing magnetic field. This **INDUCES** a **VOLTAGE** within the secondary coil.

### Transformer Symbol

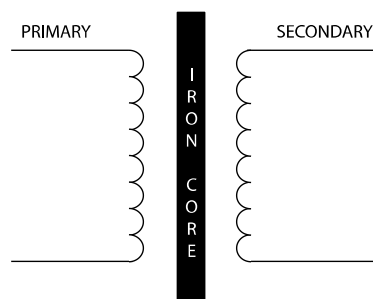

The **number of coils** of wire (or **turns**) affects the **size** of the induced **voltage**. The greater the number of turns the greater the size of voltage induced.



The following equation describes the relationship between the voltage and number of turns for the primary and secondary coils of the transformer:

$$\frac{V_s}{V_p} = \frac{N_s}{N_p}$$

**Example**

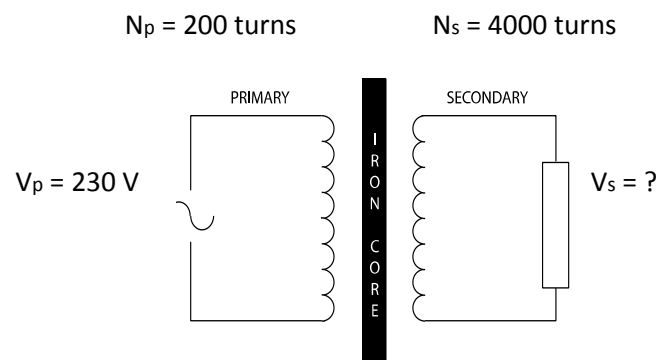

Calculate the voltage output from the secondary coil.

$V_p = 230$  V  
 $N_p = 200$  turns  
 $N_s = 4000$  turns  
 $V_s = ?$

$$\frac{V_s}{V_p} = \frac{N_s}{N_p}$$

$$\frac{V_s}{230} = \frac{4000}{200}$$

$$V_s = \frac{4000 \times 230}{200}$$

$$V_s = 4600 \text{ V}$$

## The National Grid

Electricity generated in power stations is transferred to consumers in homes, factories and businesses around the country via a network of cables known as the National grid. When a current flows through a wire some energy is lost as heat. National grid power lines may carry currents of more than 1000 A, therefore the energy losses due to heating are significant. To reduce these losses, the National Grid transmits electricity at a low current. It does this using transformers. Power stations produce electricity at 25,000 V. Upon leaving the power station, step up transformers increase the voltage to a maximum of 400,000 V with a consequent reduction in the size of the current for transmission through the National Grid power lines. These high voltages are too dangerous to use in the home or in factories, so the voltage is reduced in several stages using step-down transformers to lower the voltage to safe levels. The voltage of household electricity is about 230V.

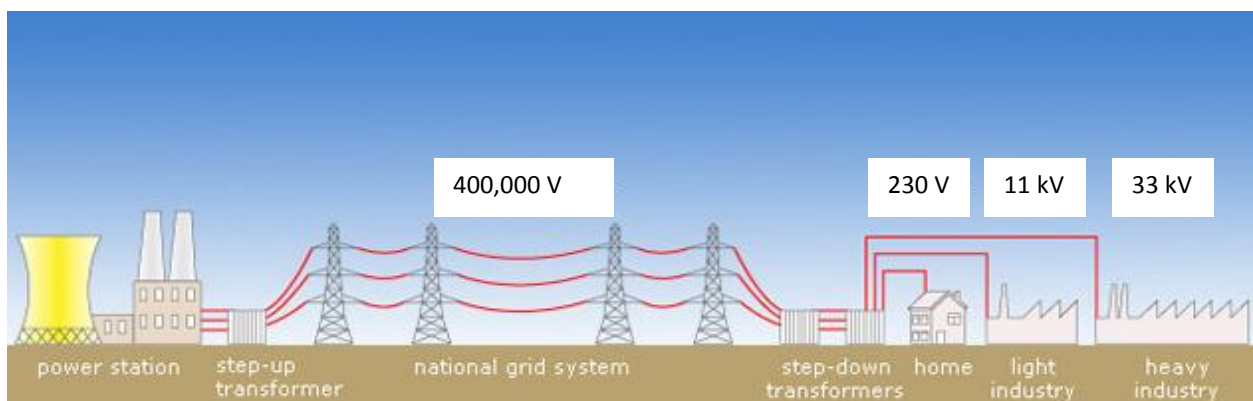

## Overhead or underground power cables

Typically, power stations are located some distance from large population centres so electricity is usually transported to where it is needed using overhead power lines. In densely built up areas, such as towns and cities, the cables tend to be buried underground. However, in areas of natural beauty, such as exist in many parts of Scotland, some people believe that overhead power lines are unattractive and have a negative impact on the environment. As a result, there is a growing debate about whether future electricity transmission systems should consist of overhead power lines or cables buried beneath the ground. In the coming decades, many more miles of power lines or cables will need to be installed to connect the growing number of remote energy sources such as wind and wave farms and nuclear power stations. Therefore, this debate is likely to become even more important as our dependence on alternative sources of energy increases.

Another factor which will influence the debate is the increasing trend towards **microgeneration** or small-scale generation of electricity by individuals and small communities to meet their own needs. This is viewed by some as a more environmentally friendly alternative to obtaining electrical power through the National Grid.

The advantages and disadvantages of overhead and underground electricity transmission systems are given below:

Overhead power lines	Underground cables
Less expensive to install	More expensive to install
More vulnerable to damage from severe bad weather	Less vulnerable to damage from severe bad weather
Easier and less expensive to repair	More difficult and more costly to repair
Large pylons are considered unattractive	Less visual impact on the environment
Long lifetime of up to 80 years before replacement	Needs replacement after only 40 years

### Efficiency

Power stations can be relatively inefficient at generating our electricity. Ranging from hydroelectric with a theoretical efficiency value of around 95%, to coal fired power stations with a theoretical efficiency of 45%. The efficiency of a power station is judged by how much useful energy is given out for the energy put in.

Percentage efficiency can be calculated using the following relationships:

$$\% \text{ efficiency} = \frac{P_{\text{out}}}{P_{\text{in}}} \times 100$$

$$\% \text{ efficiency} = \frac{E_{\text{out}}}{E_{\text{in}}} \times 100$$

### Example 1

Hunterston Power station has two reactors each producing 1496 MW of heat. The total electrical output from the power station is 1248 MW. Calculate the percentage efficiency of the power station.

$$P_{\text{in}} \text{ Useful Power input} = 2 \times 1496 \text{ MW} = 2992 \text{ MW}$$

$$P_{\text{out}} \text{ Useful Power output} = 1248 \text{ MW}$$

$$\begin{aligned} \% \text{ efficiency} &= \frac{P_{\text{out}}}{P_{\text{in}}} \times 100 \\ &= \frac{1248}{2992} \times 100 \\ &= \mathbf{41.7\%} \end{aligned}$$

### Example 2

A coal fired power station gives out 900MW of electrical energy. If the efficiency of the power station is 35%, how much coal must be used each second to give this power? (1kg of coal releases 28 MJ of energy)

$$\% \text{ efficiency} = 35\%$$

$$P_{\text{out}} \text{ Useful Power output} = 900 \text{ MW}$$

$$P_{\text{in}} \text{ Useful Power input} = ?$$

$$\begin{aligned} \% \text{ efficiency} &= \frac{P_{\text{out}}}{P_{\text{in}}} \times 100 \\ 35 &= \frac{900}{P_{\text{in}}} \times 100 \\ P_{\text{in}} &= \frac{35 \times 900}{100} \\ &= \mathbf{315 \text{ MW}} \end{aligned}$$

Power input = 315 MW, this is equivalent to 315MJ of energy input each second.

If 1kg of coal releases 28MJ of energy then:  $315 / 28 = \mathbf{11.3\text{kg of coal}}$  are needed to produce this input power.

Energy efficiency is a key factor in the generation, distribution and use of energy.

## Heat

N5

Heat and temperature are often confused. Heat is a form of energy and is measured in Joules (J). Temperature is a measure of how hot or cold something is and is measured in degrees Celsius ( $^{\circ}\text{C}$ )

If a substance gains heat, its temperature can increase. If a substance loses heat, its temperature can decrease.

The temperature of a substance is a measure of the average kinetic energy of the particles in that substance.

### Specific heat capacity

The same mass of different materials needs different quantities of heat energy to change their temperature by one degree Celsius. The ability of different substances to store different amounts of heat energy is known as the specific heat capacity of that substance. The **specific heat capacity** of a substance is defined as the amount of heat energy required to change the temperature of 1 kg of a substance by  $1^{\circ}\text{C}$ .

Specific heat capacity is calculated using the formula:

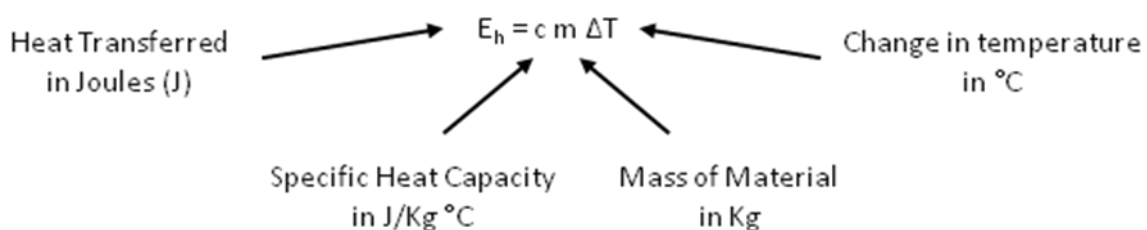

The unit for specific heat capacity is the joule per kilogram degree Celsius ( $\text{J/kg}^{\circ}\text{C}$ ).

### Example

When a kettle containing 2 kg of water (specific heat capacity  $4200 \text{ J/kg}^{\circ}\text{C}$ ) cools from  $40^{\circ}\text{C}$  to  $20^{\circ}\text{C}$ , calculate the heat given out by the water.

### Solution

$$c = 4200 \text{ J/kg}^{\circ}\text{C}$$

$$m = 2 \text{ kg}$$

$$\left. \begin{array}{l} T_2 = 40^{\circ}\text{C} \\ T_1 = 20^{\circ}\text{C} \end{array} \right\} \Delta T = 40 - 20$$

$$E_h = ?$$

$$E_h = cm\Delta T$$

$$= 4200 \times 2 \times (40 - 20)$$

$$= \underline{168000 \text{ J}}$$

## Conservation of Energy

Energy can be changed from one form to another. The principle of conservation of energy states that no energy is lost during this process. Therefore the total amount of energy before transformation is the same as the total amount of energy after transformation.

Heat energy can be produced from electrical energy in devices and appliances containing a heater:

$$\text{Electrical energy (} E_e = P t \text{ or } I t V \text{)} \longrightarrow \text{Heat energy (} E_h = cm\Delta T \text{)}$$

Some of the heat energy supplied by the heater will be “lost” to the surroundings. However, heat lost to the surroundings is ignored in heat problems

Therefore, the energy supplied by the heater = energy absorbed by the material

### Example 1

A kettle heats 0.8 kg of water ( $c_{\text{water}} = 4200 \text{ J/Kg}^\circ\text{C}$ ) and raises its temperature from  $16^\circ\text{C}$  to  $100^\circ\text{C}$ . If it takes 2 minutes to reach the final temperature, calculate the power rating of the kettle.

### Solution

#### Step 1

$$c = 4200 \text{ J/Kg}^\circ\text{C}$$

$$m = 0.8 \text{ kg}$$

$$\Delta T = 84^\circ\text{C}$$

$$E_h = ?$$

$$E_h = c m \Delta T$$

$$= 4200 \times 0.8 \times 84$$

$$= 282240 \text{ J}$$

$$= \underline{\underline{282 \text{ kJ}}}$$

#### Step 2

$$P = ?$$

$$t = 2 \text{ mins} = 120 \text{ s}$$

$$E = 282240 \text{ J}$$

$$P = E / t$$

$$= 282240 / 120$$

$$= \underline{\underline{2352 \text{ W or } 2.35 \text{ kW}}}$$

### Example 2

A kettle rated at 2.3 kW is used to heat 0.8 kg of water at 16 °C. What is the temperature of the water after 2 minutes? ( $c_{\text{water}} = 4200 \text{ J/Kg}^\circ\text{C}$ )

### Solution

#### **Step 1**

$P = 2.3 \text{ kW}$   
 $t = 2 \text{ mins} = 120 \text{ s}$   
 $E_h = ?$

$$\begin{aligned} P &= E / t \\ 2300 &= E / 120 \\ E_h &= 2300 \times 120 \\ &= \underline{\underline{276\,000 \text{ J}}} \end{aligned}$$

#### **Step 2**

$c = 4200 \text{ J/Kg}^\circ\text{C}$   
 $m = 0.8 \text{ kg}$   
 $T_1 = 16 \text{ }^\circ\text{C}$   
 $T_2 = ?$   
 $E_h = 276000 \text{ J}$

$$\begin{aligned} E_h &= c m \Delta T \\ 276000 &= 4200 \times 0.8 \times \Delta T \\ \Delta T &= 276000 / 4200 \times 0.8 \\ \Delta T &= \underline{\underline{82.1 \text{ }^\circ\text{C}}} \end{aligned}$$

#### **Step 3**

$$\begin{aligned} \Delta T &= T_2 - T_1 \\ 82.1 &= T_2 - 16 \\ T_2 &= 82.1 + 16 \\ T_2 &= \underline{\underline{98.1 \text{ }^\circ\text{C}}} \end{aligned}$$

## Conservation of Energy

### The Principle of Conservation of Energy

Energy can be changed from one form into another but *it cannot be created or destroyed*.  
Energy *is always conserved*.

As energy transforms from one form into another, some energy may be lost. For example in a light bulb the main energy change is electrical into light however some of the energy is lost in the form of heat.

### Transformations

- |              |                   |       |                   |
|--------------|-------------------|-------|-------------------|
| • Light bulb | electrical energy | ————→ | light + (heat)    |
| • Hoover     | electrical energy | ————→ | kinetic + (sound) |
| • Cooker     | electrical energy | ————→ | heat + (light)    |

### Work Done

When an object is moved from one place to another, energy has to be transformed to do this.

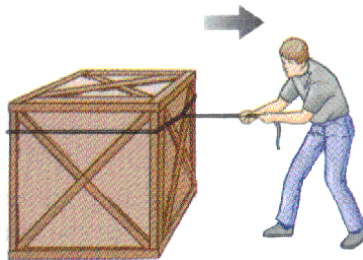

To pull this box along the ground Joey transfers his chemical energy into work done.

The amount of energy transferred (work done) will depend on:

- The force applied to the box.
- The distance the box has been pulled from its original position (displacement)

Work done has the symbol  $E_w$  and is measured in joules, J

Force has the symbol  $F$  and is measured in Newtons, N.

Displacement has the symbol  $s$  and is measured in metres, m.

**Work done = force x displacement**

$$E_w = F \times s$$



Carry out calculation using  $E_w = F \times s$

### Example

Calculate the work done in pulling the 2 kg box from point A to B.

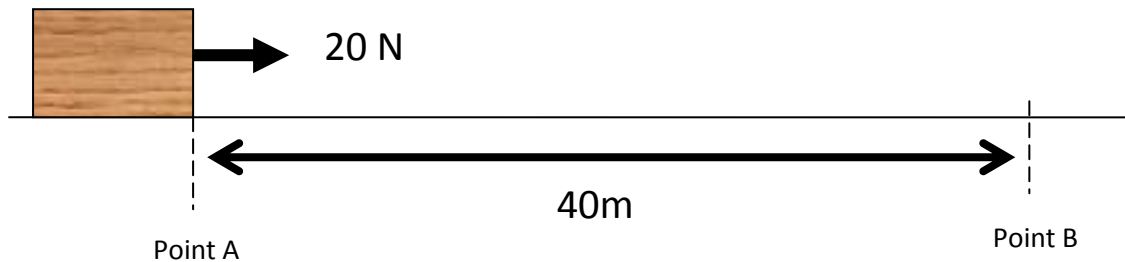

$E_w = ?$	}	$E_w = F \times s$
$F = 20 \text{ N}$		$E_w = 20 \times 40$
$s = 40 \text{ m}$		$E_w = 800 \text{ J}$

### Gravitational Potential Energy

Gravitational potential energy is the work done against gravity.



The 2 kg box has to be lifted up 20 m onto the shelf above it. The work done against gravity can be calculated using  $E_w = F \times s$ .

Where,  $F = \text{weight of the box} = m \times g = 2 \times 10 = 20 \text{ N}$

$s = \text{the height} = 20 \text{ m}$

$E_w = \text{the change in gravitational potential energy, } \Delta E_p$

Therefore an equation more relevant to the problem can be written:

Change in Potential energy = mass x gravitational field strength x height

$$\begin{aligned}\Delta E_p &= m \times g \times h \\ &= 2 \times 10 \times 20 \\ &= 400 \text{ J}\end{aligned}$$

### Kinetic Energy

Kinetic energy is the energy an object has because it is moving. Kinetic energy has the symbol  $E_k$  and is measured in joules, J.

The kinetic energy an object has depends on the mass and velocity of the object they are related as follows:

kinetic energy =  $\frac{1}{2} \times \text{mass} \times \text{velocity}^2$

$$E_k = \frac{1}{2} \times m \times v^2$$

↑
↑
↑  
 Joules, J                      kilograms, kg                      metres per second, m/s

### Calculations involving energy transformations using the Principle of Conservation of Energy

As an object falls from a height its gravitational potential energy is transformed into other forms. If there are no energy losses all the gravitational potential energy would be converted into kinetic energy.

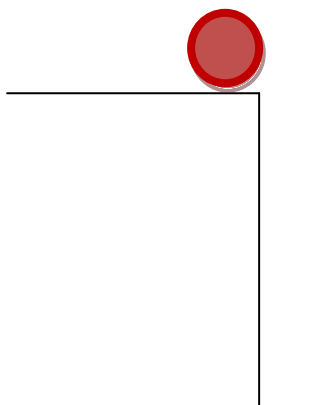

As the balls falls all its  $E_p$  is transformed into  $E_k$

Therefore

$$E_p = E_k$$

$$m \times g \times h = \frac{1}{2} \times m \times v^2 \quad (\text{m's cancel})$$

$$g \times h = \frac{1}{2} \times v^2$$

$$\sqrt{2gh} = v$$

### Example

A model car has a mass of 0.5 kg, it starts from rest and is allowed to roll down a slope.

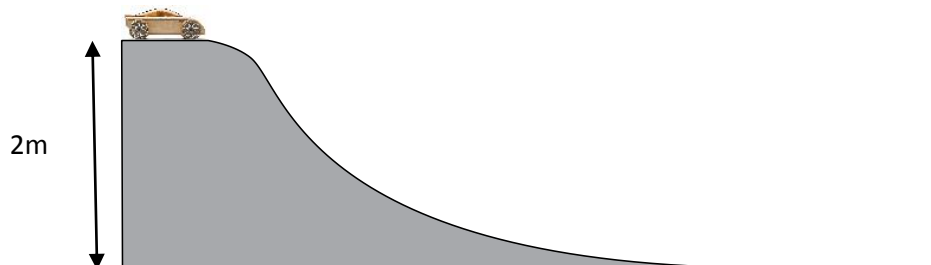

- Calculate the amount of gravitational potential energy it loses as it runs down the slope.
- Ignoring any energy losses state its gain in kinetic energy as it runs down to the bottom of the slope.
- Calculate the speed of the model car at the bottom of the slope.

### Solutions

(a)  $E_p = m \times g \times h$   
 $= 0.5 \times 10 \times 2$   
 $= 10 \text{ J}$

(b)  $E_k = 10 \text{ J}$ , since all potential energy is converted into kinetic energy as no energy is lost.

(c)  $v = \sqrt{2gh}$   
 $v = \sqrt{2 \times 10 \times 2}$   
 $= \sqrt{40}$   
 $= 6.3 \text{ m/s}$

The Three States of Matter

**Kinetic** - movement

**Matter** - what everything is made up of (particles)

A kinetic model of matter explains how the *particles* which make up solids, liquids and gases are arranged and how they move around.

The diagrams below show how the particles in solids, liquids and gases are arranged.

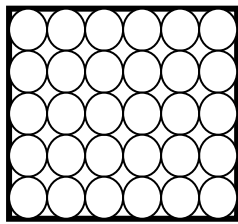

SOLID

**Arranged:** Particles very close together.

**Move:** particles vibrate in the one spot.

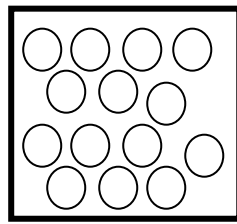

LIQUID

**Arranged:** Particles close together.

**Move:** particles swap places with their nearest neighbouring particles.

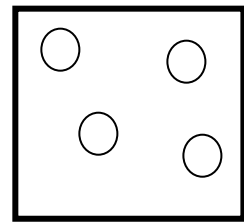

GAS

**Arranged:** Particles far apart.

**Move:** particles move very fast randomly around in all directions.

Kinetic Theory of Gases

**Pressure varies with Volume**

A gas half fills a glass tube and is held in position with a tightly fitting piston.

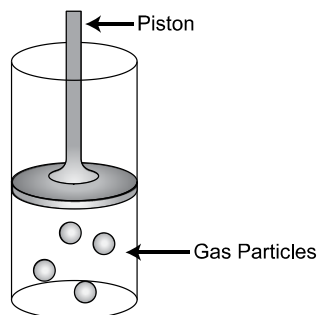

The gas particles are moving around very fast in all directions. The gas particles are colliding with each other and with the sides of the glass tube, thus creating a *pressure* inside.

What would happen if the piston was moved to the end of the glass tube?

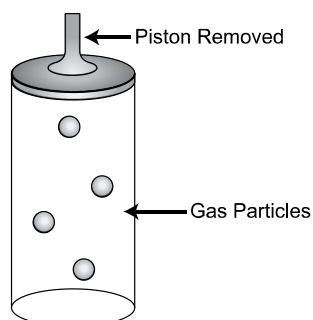

The gas particles will move to fill up the whole of the glass tube

How will this affect the **pressure** inside the glass tube?

The pressure will be reduced since there is more space for the particles to move around. Therefore the particles will collide less often with each other and they will collide less often with the sides of the container.

*As the volume increases the pressure decreases.*

### Pressure varies with Temperature

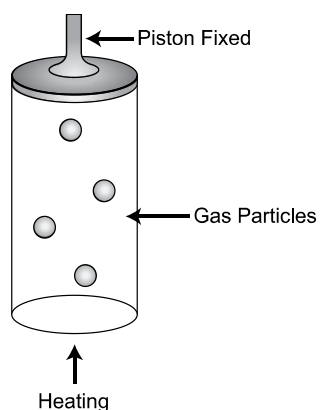

As the gas inside the glass tube is heated the gas particles gain more kinetic energy. This causes them to collide more often with each other and the walls of the container, causing an increase in pressure

*As the temperature increases the pressure increases.*

## Volume varies with Temperature

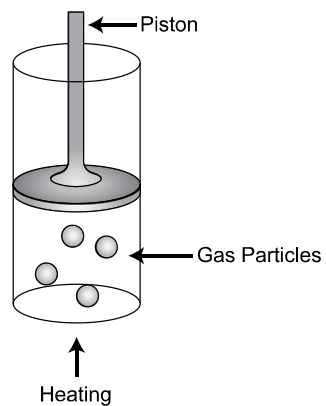

As the gas inside the glass tube is heated the gas particles gain more kinetic energy. This causes them to collide more often with each other and the walls of the container, causing an increase in pressure on the glass tube and the piston.

As the piston is not fixed the pressure will *force the piston upwards* increasing the volume the gas takes up within the glass tube.

*As the temperature increases the volume increases.*

## Applications of the kinetic model of a gas

### Example 1

As pressure increases, volume decreases and vice versa for a fixed mass of gas.

In deep water the pressure on a body is less nearer the surface of the water than it is close to the sea bed.

This is due to the increase in the amount of water on top of the body. The greater the volumes of water on top of the body, the greater the pressure the body feels.

When a fish adapted to life in deep water is brought to the surface, the pressure on it decreases. Therefore, its volume of gas in the fish's body increases, causing their air bladders, cells and membranes to 'pop', ending their lives.

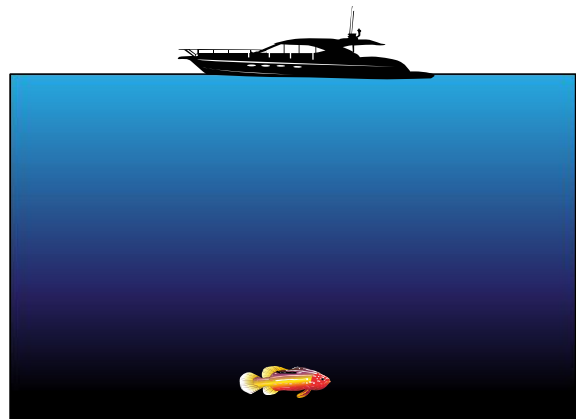

### Example 2

As pressure increases, temperature increases and vice versa for a fixed mass of gas.

In summer time when the outside temperature is hotter than normal, a car tyre may explode.

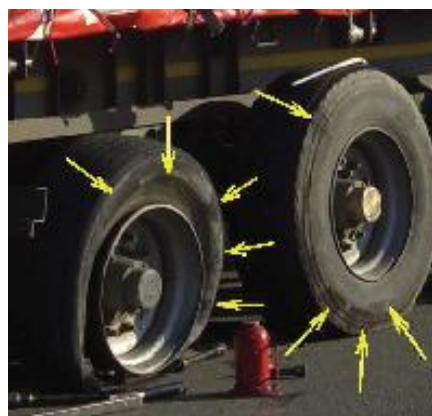

This happens as the gas particles are exposed to an increase in temperature. This causes them to gain more kinetic energy and causes the pressure of the air inside the tyre to increase.

### Example 3

As temperature increases, volume increases and vice versa for a fixed mass of gas.

A football inflated inside then taken outside on a cold winter's day will shrink slightly.



This happens since the air inside the ball is exposed to a colder temperature, causing the kinetic energy of the particles of air to decrease. Therefore, the particles of the air collide less often with the walls of the ball and the pressure inside the ball decreases. Therefore the ball shrinks.



## Pressure

N5

Pressure can be described as the force exerted on a surface per one metre squared.

The greater the force on 1 m<sup>2</sup>, the greater the pressure exerted on the surface and vice versa.

$$\text{pressure} = \frac{\text{force}}{\text{area}}$$
$$P = \frac{F}{A}$$

← Newtons, N

← metre squared, m<sup>2</sup>

↗ Newtons per metre squared, N/m<sup>2</sup>

Pressure is measured in units of Newtons per metre squared, N/m<sup>2</sup> or Pascals, Pa.

**Remember:** when calculating the total pressure at a depth in water, you must take into account the pressure due to the atmosphere = 1 x 10<sup>5</sup> Pa.

### Example 1

A box has a weight of 650 N and has dimensions 0.5m by 2m, what pressure is exerted on the floor?

$$F = 650 \text{ N}$$

$$A = (0.5 \times 2) \text{ m}^2 = 1 \text{ m}^2$$

$$P = ?$$

$$P = \frac{F}{A}$$

$$P = \frac{650}{1}$$

$$P = 650 \text{ N/m}^2$$

### Example 2

A girl has a mass of 40kg, her shoes have dimensions 0.25 m by 0.1 m, what pressure does she exert on the with one foot?

$$F = W = m \times g = 40 \times 10 = 400 \text{ N}$$

$$A = 0.25 \times 0.1 = 0.025 \text{ m}^2$$

$$P = ?$$

$$P = \frac{F}{A}$$

$$P = \frac{400}{0.025}$$

$$P = 16\,000 \text{ N/m}^2$$

**Think:** when is the *pressure* of the girl on the floor at *its greatest*? when standing one foot or two feet.

## Kinetic Theory of Gases

The kinetic theory of gases is used to explain the behaviour of gases using a model. The model considers a gas to be composed of a large number of very small particles that are widely spaced. The particles are moving at random in all directions with a range of speeds. No energy is lost when the particles collide with the walls of the container and each other.

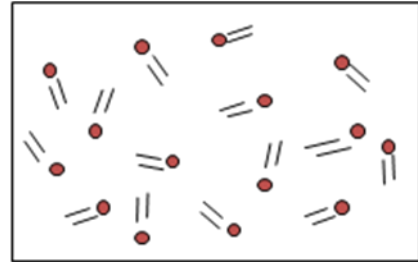

## Volume

The volume of a gas is taken as the volume of the container. The volume occupied by the gas particles themselves is considered so small as to be negligible.

## Temperature

The temperature of a gas depends on the kinetic energy of the gas particles. The faster the particles move, the greater their kinetic energy and the higher the temperature.

## Pressure

The pressure of a gas is caused by the particles colliding with the walls of the container. The more frequent these collisions or the more violent these collisions, the greater will be the pressure.

## Relationship between Pressure and Volume of a Gas

Consider an experiment to determine the relationship between pressure and volume of a fixed mass and fixed volume of gas.

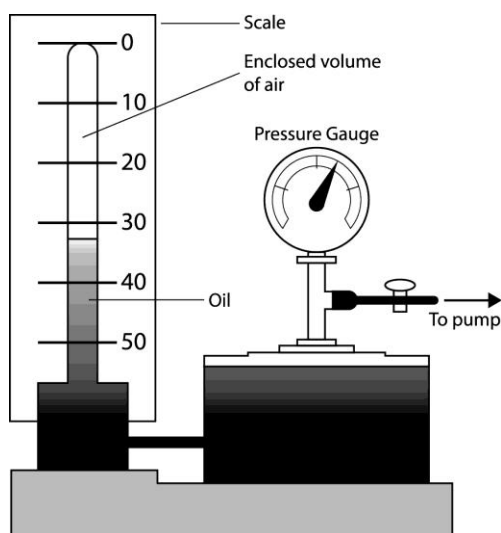

- As the pump varies the pressure, the volume of the enclosed gas is measured
- It is found that as the pressure increases, the volume decreases

Boyle's law states that for a fixed mass of gas at a constant temperature, the pressure of a gas is inversely proportional to its volume:

$$p \propto \frac{1}{V}$$

$$p \times V = \text{constant}$$

$$p_1 V_1 = p_2 V_2$$

### Graph

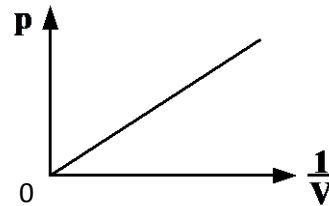
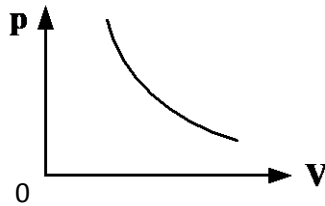

### Example

The pressure of a gas enclosed in a cylinder by a piston changes from 80 kPa to 200 kPa.

If there is no change in temperature and the initial volume was 25 litres, calculate the new volume.

$$p_1 = 80 \text{ kPa}$$

$$p_1 V_1 = p_2 V_2$$

$$V_1 = 25 \text{ litres}$$

$$80 \times 25 = 200 \times V_2$$

$$p_2 = 200 \text{ kPa}$$

$$\underline{V_2 = 10 \text{ litres}}$$

$$V_2 = ?$$

## Relationship between Pressure and Temperature of a Gas

Consider an experiment to determine the relationship between pressure and temperature of a fixed mass and fixed volume of gas.

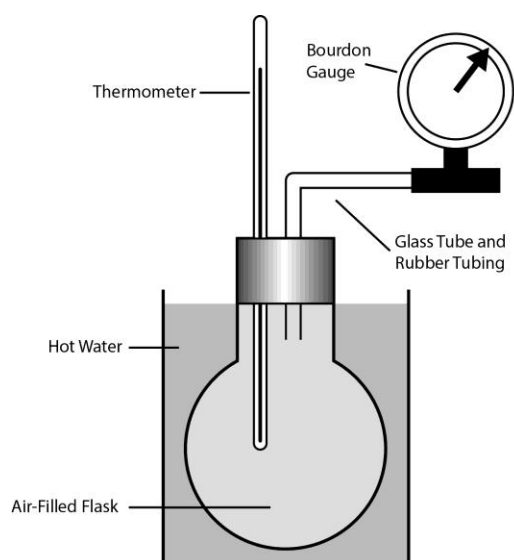

- As the water is heated, the pressure of the gas is measured
- It is found that as the temperature increases, the pressure increases

If a graph is drawn of pressure against temperature in degrees celsius for a fixed mass of gas at a constant volume, the graph is a straight line which does not pass through the origin. When the graph is extended until the pressure reaches zero, it crosses the temperature axis at  $-273\text{ }^{\circ}\text{C}$ . This is true for all gases:

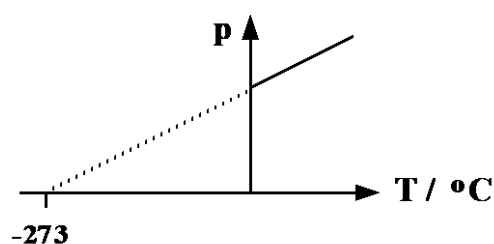

### Kelvin Temperature Scale

The temperature  $-273^{\circ}\text{C}$  is called **absolute zero** and is the zero on the Kelvin temperature scale. At a temperature of absolute zero, 0 K, all particle motion stops and this is therefore the lowest possible temperature.

One division on the kelvin temperature scale is the same size as one division on the celsius temperature scale, i.e. temperature **differences** are the same in kelvin as in degrees Celsius e.g. a temperature increase of  $10^{\circ}\text{C}$  is the same as a temperature increase of 10 K.

Note: the unit of the kelvin scale is the kelvin, K, **not** degrees kelvin,  $^{\circ}\text{K}$ !

## Converting temperatures between °C and K

Converting °C to K                      add 273

Converting K to °C                      subtract 273

If the graph of pressure against temperature is drawn using the kelvin temperature scale, zero on the graph is the zero on the kelvin temperature scale and the graph now goes through the origin:

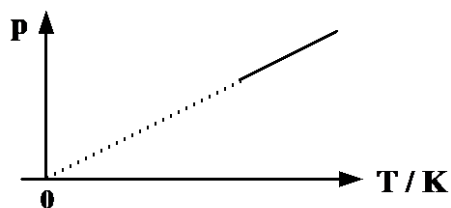

Gay Lussac's law states that for a fixed mass of gas at a constant volume, the pressure of a gas is directly proportional to its temperature measured in kelvin (K):

$$p \propto T$$

$$\frac{p}{T} = \text{constant}$$

$$\frac{p_1}{T_1} = \frac{p_2}{T_2}$$

### Example

Hydrogen in a sealed container at 27 °C has a pressure of  $1.8 \times 10^5$  Pa. If it is heated to a temperature of 77 °C, what will be its new pressure?

$$p_1 = 1.8 \times 10^5 \text{ Pa}$$

$$p_1 / T_1 = p_2 / T_2$$

$$T_1 = 27 \text{ °C} = 300 \text{ K}$$

$$1.8 \times 10^5 / 300 = p_2 / 350$$

$$p_2 = ?$$

$$p_2 = \underline{2.1 \times 10^5 \text{ Pa}}$$

$$T_2 = 77 \text{ °C} = 350 \text{ K}$$

## Relationship between Volume and Temperature of a Gas

Consider an experiment to determine the relationship between volume and temperature of a fixed mass of gas at a constant pressure.

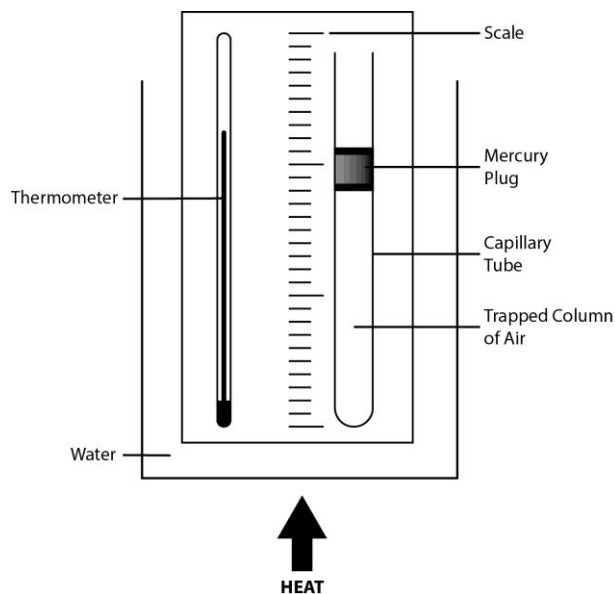

- As the water is heated, the volume of the gas is measured
- It is found that as the temperature increases, the volume increases

If a graph is drawn of volume against temperature, in degrees celsius, for a fixed mass of gas at a constant pressure, the graph is a straight line which does not pass through the origin. When the graph is extended until the volume reaches zero, again it crosses the temperature axis at  $-273\text{ }^{\circ}\text{C}$ . This is true for all gases

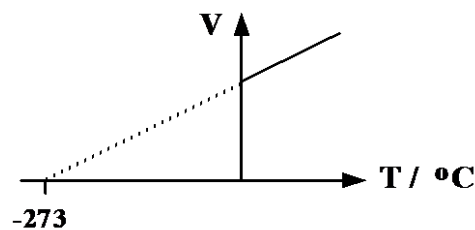

If the graph of volume against temperature is drawn using the kelvin temperature scale, the graph now goes through the origin:

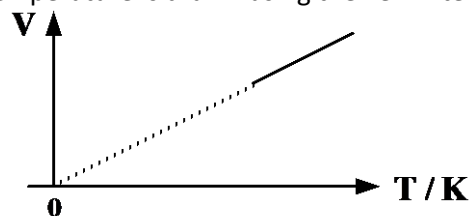

Charles' law states that for a fixed mass of gas at a constant pressure, the volume of a gas is directly proportional to its temperature measured in kelvin (K):

$$V \propto T$$

$$\frac{V}{T} = \text{constant}$$

$$\frac{V_1}{T_1} = \frac{V_2}{T_2}$$

### Example

400 cm<sup>3</sup> of air is at a temperature of 20 °C. At what temperature will the volume be 500 cm<sup>3</sup> if the air pressure does not change?

$$V_1 = 400 \text{ cm}^3$$

$$T_1 = 20 \text{ }^\circ\text{C} = 293 \text{ K}$$

$$V_2 = 500 \text{ cm}^3$$

$$T_2 = ?$$

$$\frac{V_1}{T_1} = \frac{V_2}{T_2}$$

$$\frac{400}{293} = \frac{500}{T_2}$$

$$\underline{T_2 = 366 \text{ K} = 93 \text{ }^\circ\text{C}}$$

Note: convert back to the temperature scale used in the question

### Combined Gas Equation

By combining the above three relationships, the following relationship for the pressure, volume and temperature of a fixed mass of gas is true for all gases.

$$\frac{p \times V}{T} = \text{constant}$$

$$\frac{p_1 V_1}{T_1} = \frac{p_2 V_2}{T_2}$$

### Example

A balloon contains 1.5 m<sup>3</sup> of helium at a pressure of 100 kPa and at a temperature of 27 °C. If the pressure is increased to 250 kPa at a temperature of 127 °C, calculate the new volume of the balloon.

$$p_1 = 100 \text{ kPa}$$

$$V_1 = 1.5 \text{ m}^3$$

$$T_1 = 27 \text{ }^\circ\text{C} = 300 \text{ K}$$

$$p_2 = 250 \text{ kPa}$$

$$V_2 = ?$$

$$T_2 = 127 \text{ }^\circ\text{C} = 400 \text{ K}$$

$$\frac{p_1 V_1}{T_1} = \frac{p_2 V_2}{T_2}$$

$$\frac{100 \times 1.5}{300} = \frac{250 \times V_2}{400}$$

$$V_2 = \underline{0.8 \text{ m}^3}$$

## Gas Laws and the Kinetic Theory of Gases

### Pressure - Volume (constant mass and temperature)

Consider a volume  $V$  of gas at a pressure  $p$ . If the volume of the container is reduced without a change in temperature, the particles of the gas will hit the walls of the container more often (but not any harder as their average kinetic energy has not changed). This will produce a larger force on the container walls. The area of the container walls will also reduce with reduced volume. As volume decreases, then the force increases and area decreases resulting in, from the definition of pressure, an increase in pressure i.e. volume decreases hence pressure increases and vice versa.

### Pressure - Temperature (constant mass and volume)

Consider a gas at a pressure  $p$  and temperature  $T$ . If the temperature of the gas is increased, the kinetic energy and hence speed of the particles of the gas increases. The particles collide with the container walls more violently and more often. This will produce a larger force on the container walls. As temperature increases, then the force increases resulting in, from the definition of pressure, an increase in pressure,

i.e. temperature increases hence pressure increases and vice versa.

### Volume - Temperature (constant mass and pressure)

Consider a volume  $V$  of gas at a temperature  $T$ . If the temperature of the gas is increased, the kinetic energy and hence speed of the particles of the gas increases. If the volume was to remain constant, an increase in pressure would result as explained above. If the pressure is to remain constant, then the volume of the gas must increase to increase the area of the container walls that the increased force is acting on, i.e. volume increases hence pressure increases and vice versa.

## Practical Electronic Systems

N4

An electrical system is a collection of components connected together to perform a particular job.

All electronic systems can be broken down into three main parts or sub-systems called the **input**, the **process** and the **output**

An electronic system is often drawn as a block diagram showing how information is passed from one block to another:

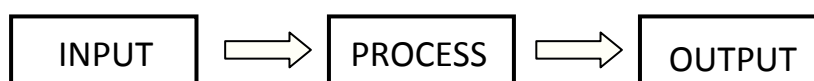



For example, a baby alarm consists of three main parts:

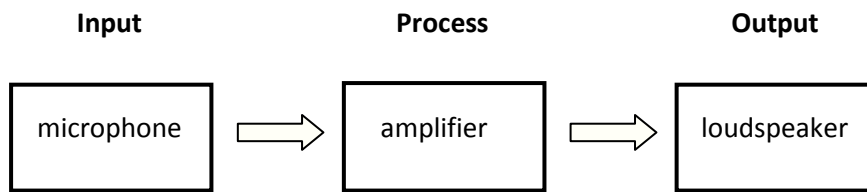

The **input** changes sound energy into electrical energy.

The **process** amplifies this energy to produce the electrical energy needed to work the output.

The **output** converts the electrical energy back into sound energy.

Examples of block diagrams:

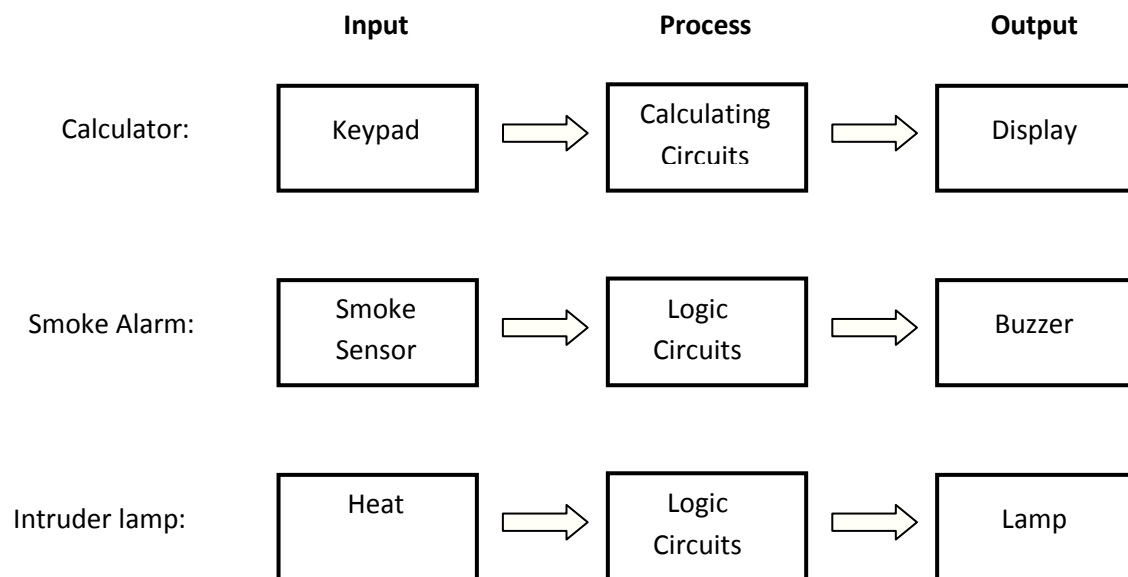

### Input devices

An input device changes some form of energy into electrical energy.

Examples of input devices:

A microphone changes sound energy into electrical energy.

A thermistor is a resistor, the resistance of which varies with temperature. As the temperature increases, the resistance decreases.

### Circuit Symbol



An LDR is a light dependant resistor, the resistance of which varies with light level. As the light intensity increases, the resistance decreases.

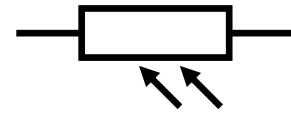

A switch makes or breaks a circuit depending on the setting.



Summary of input condition and resistance:

Device	Condition	Resistance
Thermistor	Low temperature	High
	High temperature	Low
Light Dependant Resistor	Dark	High
	Light	Low
Switch	Open	Very, very high
	Closed	Low

Examples of input applications:





Application	Device	Reason
Input of a loudspeaker	Microphone	The microphone changes sound waves into electrical signals
Input of a heating system	Thermistor	The thermistor will change resistance when the temperature changes
Input of an automatic lamp	LDR	The LDR will change resistance when the brightness changes
Input of a lighting circuit	Switch	The switch will make or break the circuit when the setting is changed

### Output devices

An output device changes electrical energy into another form of energy.

Examples of output devices:

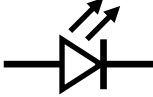
Device	Circuit Symbol	Energy Change
Loudspeaker		Electrical energy $\longrightarrow$ Sound Energy

Buzzer		Electrical energy → Sound energy
Lamp		Electrical energy → Light energy
LED		Electrical energy → Light energy
Motor		Electrical energy → Kinetic energy

Examples of output applications:

Application	Device	Reason
Output of a radio	Loudspeaker	The output from the loudspeaker is sound waves
Output of a smoke alarm	Buzzer	A voltage across the buzzer makes it sound
Output of a security lamp	Lamp	A voltage across the lamp makes it light
Output of an warning light	LED	A voltage across the LED makes it light
Output of a fan	Motor	The motor will turn the blades of the fan

### Logic Gates

There are three basic types of logic gates. Their symbols are:

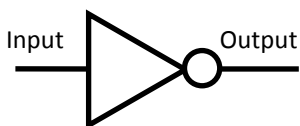

NOT

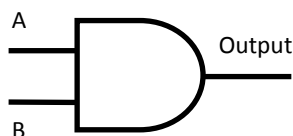

AND

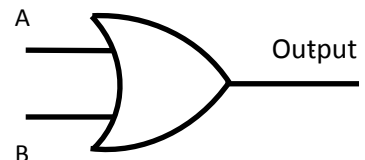

OR

Digital signals are either on or off.

An 'off' signal has a zero voltage (called 'low'). An 'on' signal has a non-zero voltage (called 'high').

The **zero voltage** signal is given the name '**logic 0**'. The **high voltage** signal is given the name '**logic 1**'.

### Logic Gate Output

- NOT gate the output is the opposite of the input.
- AND gate both inputs need to be high for the output to be high.
- OR gate either input need to be high for the output to be high.

### Truth tables

Truth tables show the output for all combinations of inputs for logic gates.

Not gate

Input	Output
0	1
1	0

AND gate

Input (A)	Input (B)	Output
0	0	0
0	1	0
1	0	0
1	1	1

OR gate

Input (A)	Input (B)	Output
0	0	0
0	1	1
1	0	1
1	1	1

## Combination of logic gates

Logic gates may be combined together to increase the number of input variables.

This helps to control situations where the output may depend on having more than one dependent input variable.

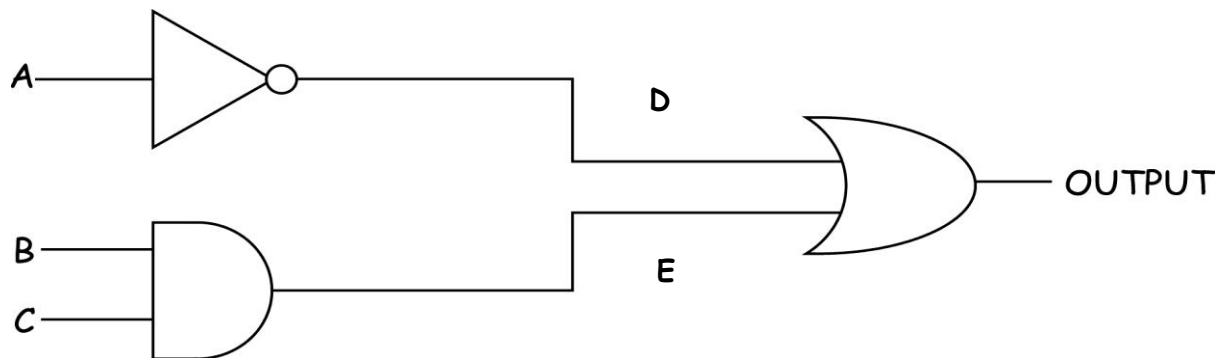

INPUT (A)	INPUT (B)	INPUT (C)	INPUT (D)	INPUT (E)	OUTPUT (D OR E)
0	0	0	1	0	1
0	0	1	1	0	1
0	1	0	1	0	1
0	1	1	1	1	1
1	0	0	0	0	0
1	0	1	0	0	0
1	1	0	0	0	0
1	1	1	0	1	1

### Example 1

Draw a truth table and logic diagram for a warning **LED to light**, when a car **engine gets too hot** (logic 1). The lamp should only operate when the **ignition** of the car is switched **on**, (logic 1).

- Draw a truth table considering all possible situations for the input sensors.

Temperature Sensor	Ignition switch	LED
Cold (0)	Off (0)	Off (0)
Cold (0)	On (1)	Off (0)
Warm (1)	Off (0)	Off (0)
Warm (1)	On (1)	On (1)

- Look carefully at the resulting logic to decide which combination of logic gates would resolve the input to produce the desired output.

This example requires an AND gate to solve.

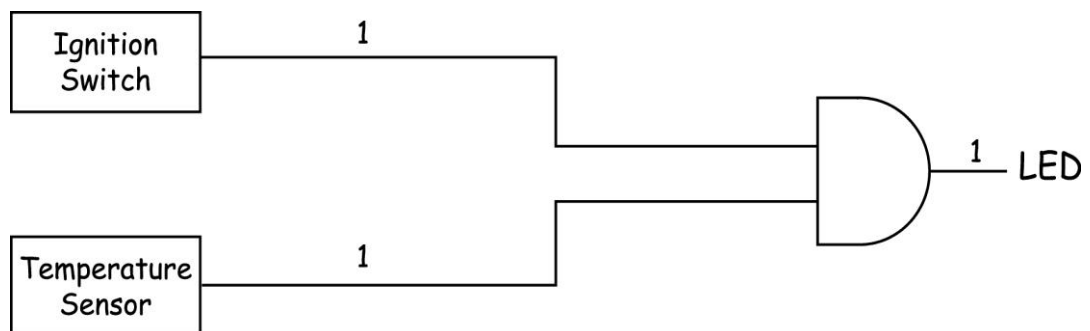

## Example 2

Draw a truth table and logic gate diagram which will **switch on the pump** of a central heating system, when the **house is cold** (logic **0**) and the **central heating** is switched **on** (logic **1**).

Temperature Sensor	Central Heating switch	Pump
Cold <b>(0)</b>	Off <b>(0)</b>	Off <b>(0)</b>
Cold <b>(0)</b>	On <b>(1)</b>	On <b>(1)</b>
Warm <b>(1)</b>	Off <b>(0)</b>	Off <b>(0)</b>
Warm <b>(1)</b>	On <b>(1)</b>	Off <b>(0)</b>





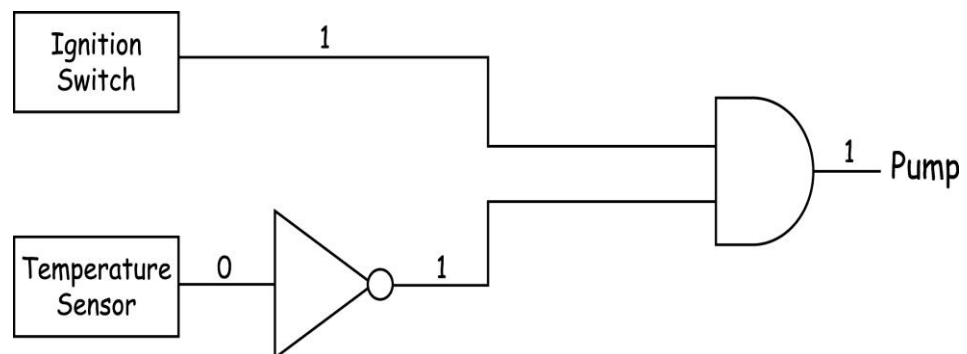

The output for the pump is AND logic. Both inputs should be logic 1 to switch on the pump.

When the house is cold, the output from the temperature sensor is logic 0. Therefore, you need to insert a NOT gate to change the output from logic 0 to logic 1.

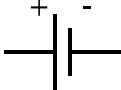
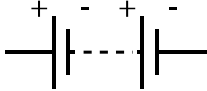
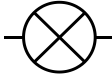

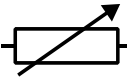

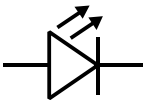
## Summary of electronic components

N5

Electronic Component	Symbol	Function	Practical Application
Cell		Converts chemical energy into electrical energy	Supplies energy to a car battery
Battery		Converts chemical energy into electrical energy	Supplies energy to a torch
Lamp		Converts electrical energy into light	Bulb
Switch		To complete a circuit	Allows a circuit to be switch on or off
Resistor		To limit the current in a circuit	Changes electrical energy into heat in a toaster
Variable resistor		To vary to current in a circuit.	To vary the amount of current to a dimmer lamp
Voltmeter		To measure the voltage between two points. (p.d)	Measures the voltage through a component
Ammeter		To measure the current flow (charge per second) in a circuit / component	Measures the charge per second through a component
LED		To convert electrical energy into light	To act as a warning light. TV stand by
Motor		To convert electrical energy into kinetic energy	To allow the rotation of a washing machine drum
Loudspeaker		To convert electrical energy into kinetic energy - produces sound energy	To listen to music Telephone handset

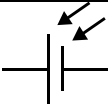
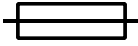

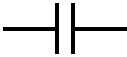
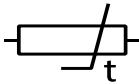
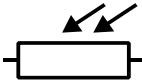
Electronic Component	Symbol	Function	Practical Application
Photovoltaic cell		To convert light energy into electrical energy	Calculator
Fuse		To limit the current flowing into a circuit	Melts and breaks when the flow of current is too high
Diode		To block the flow of current in one direction	Will only allow a.c to flow in one direction around a circuit.  Used in radios and TV to convert radio or TV signals
Capacitor		To store electric charge	Used in timing circuits to produce a time delay. Traffic lights
Thermistor		When its temperature increases its resistance decreases and vice versa	Used as an input device to a central heating system.
LDR		When the light levels on it decrease, its resistance increases.	Light sensor which switches on a lamp at dusk

## Potential Dividers

A potential divider circuit is made up with resistors or other components connected across a supply.

For example:

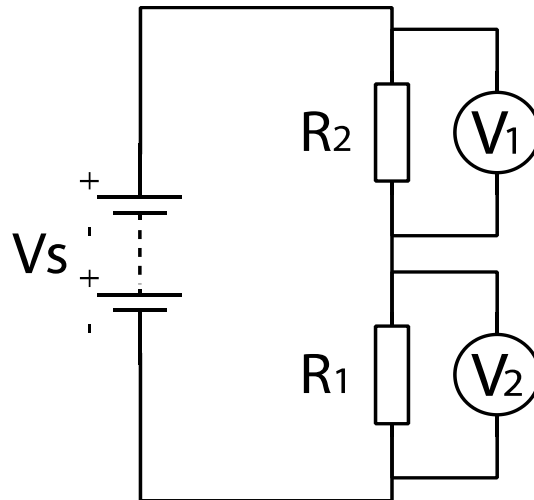

Drawn as above, the potential divider circuit is simply a series circuit following all the same rules; the current is the same at all points and the supply voltage splits up across each component to give them a share of the voltage (or potential difference).

Through experimentation the following relationships can be derived:

$$\frac{V_1}{V_2} = \frac{R_1}{R_2}$$

$$V_1 = \frac{R_1}{R_1 + R_2} \times V_{\text{supply}}$$

and

$$V_2 = \frac{R_2}{R_1 + R_2} \times V_{\text{supply}}$$

### Example 1

Calculate the potential difference  $V_1$ .

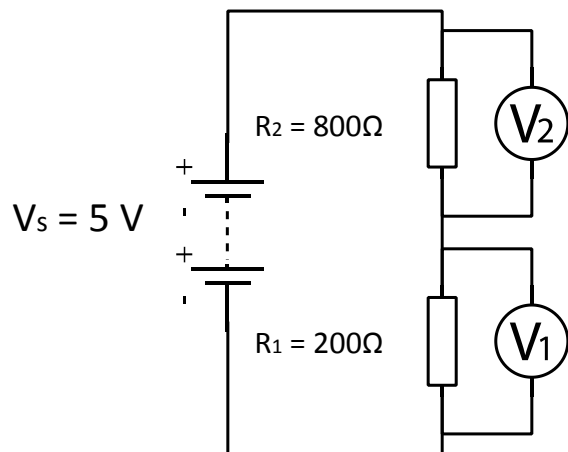

$$V_1 = \frac{R_1}{R_1 + R_2} \times V_{\text{supply}}$$

$$V_1 = \frac{200}{200 + 800} \times 5$$

$$\underline{V_1 = 1\text{ V}}$$

### Example 2

The resistance of the LDR,  $R_1$  in the dark is  $10\text{ k}\Omega$  and when in the light its resistance is  $1\text{ k}\Omega$ .

Calculate the value of  $V_1$  when the LDR is in the dark.

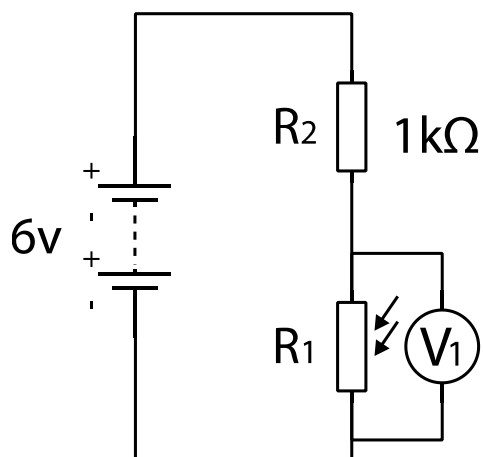

$$V_1 = \frac{R_1}{R_1 + R_2} \times V_{\text{supply}}$$

$$V_1 = \frac{10\,000}{10\,000 + 1\,000} \times 6$$

$$\underline{V_1 = 5.45\text{ V}}$$

## Transistor

A transistor is a **process** device. It acts as an **automatic switch**.

### Symbol

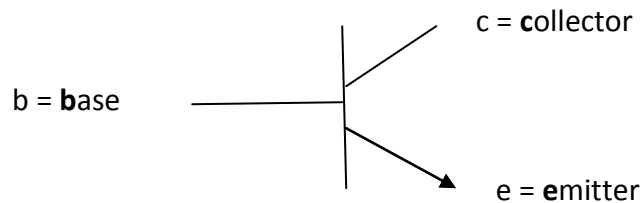

Electrons flow from the emitter through the base to the collector. This only happens if the **voltage across the base /emitter** is high enough.

**The conducting voltage is 0.7V - ON**

Anything less and the transistor will not allow current to flow through it. Below 0.7 V the transistor is non-conducting - OFF.

### **Example**

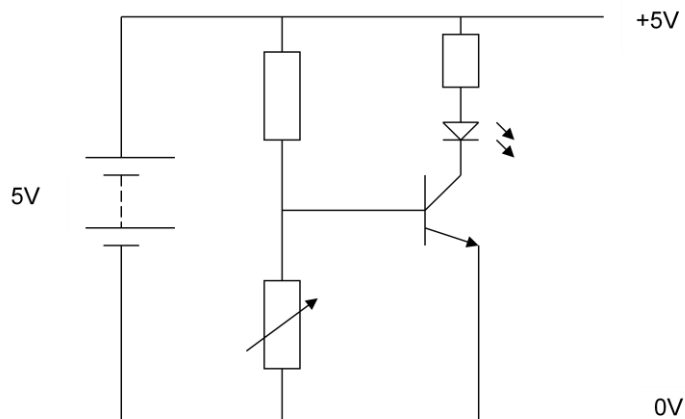

As the **resistance of the variable resistor is gradually increased**, the voltage across it increases and the voltage applied to the emitter- base increases. When the voltage applied to the emitter-base of the transistor is 0.7 V or more, the transistor will **switch on** and conduct allowing current to flow through it to the LED and the LED will switch 'on'.